



ARCONIC



AUTHORIZED DISTRIBUTOR

Tel.: +91 80 29722055

E-Mail: sales@recoil.in

RECOIL® Technical Catalogue



www.recoil.in



Table of Contents

Introduction	3	Unified Fine - UNF	37 Recoil
Recoil Range	4	Locking Insert Torque Values	40 Recoil Part
How a Recoil Insert Works	5	Numbers Cross Reference -	
How a Locking Insert Works	9	Tanged and Tangless - Locking Series	
Recoil Tangless Inserts	10	Metric	41 Unified Coarse
Materials and Coatings	11	- UNC	48
Materials	12	Unified Fine - UNF	51
Finishes and Coatings	13	Recoil Strip-Feed Inserts	54
Corrosion Protection	15	Recoil Strip Feed Part Numbers -	
Recoil Tapped Hole Dimensions - Standard		Tanged and Tangless	
Metric	16	Metric	54 Unified
Unified Coarse - UNC	18	Coarse / Fine - UNC / UNF	56
Unified Fine - UNF	19	Recoil Tapped Hole Dimensions -	
Recoil Tapped Hole and Fitted Size Data -		BS / 8UN / NPT / BA	
Metric Sizes Tanged and Tangless	20	BSW	59
Recoil Tapped Hole and Fitted Size Data -		BSF	60
Unified Coarse Tanged and Tangless - UNC	21	BSP	62
Recoil Tapped Hole and Fitted Size Data -		8UN	63
Unified Fine Tanged and Tangless - UNF	22	Design and Installation Data - NPT and ANPT	64 Process
Recoil Insert Dimensions		Sheet - NPT and ANPT	66 BA
Recoil Inserts Metric	23	Recoil Thread	
Inserts Unified Coarse & Fine	25	Insert Part Numbering System	27
Dimensional Data	26	Recoil Part Numbers Cross Reference -	
Recoil Thread		Tanged and Tangless - Free Running Series	
Recoil STI Taps	69	Metric	28
Tap Terminology	72	Unified Coarse - UNC	34
Recoil STI Taps -		Recoil Part Numbers Cross Reference -	
Part Numbers and Dimensions		Tanged and Tangless - Free Running Series	
Metric Coarse	73	Metric	28
Metric Fine	74	Unified Coarse - UNC	34
Coarse & Fine - UNC / UNF	75	BSW / BSF / BSC	
/ BSP	76		

Table of Contents

Recoil STI Taps - Part Numbers and Dimensions

BA / NPT / 8 TPI UN	77	Recoil Kits and Hand Installation Tools	98 Recoil
Recoil STI Thread Gauges	78	Kits and Hand Installation Tool	
Unified Coarse / Fine - UNC / UNF	78	Part Numbers	99
Metric Coarse & Metric Fine	79	Design Considerations	102
Recoil Driver Tools	80	Assembly Design	103 Thread
Recoil Tooling Options	81 Recoil	Identification and Drill Chart	107 General
Thread Insert Tooling		Information	109
Part Numbering System	81		
REC-10K Air Driver	82 Recoil		
Front End Assembly (FEA)			
Part Numbers - Tanged and Tangless	84		
Recoil Front End Assembly (FEA)			
Tool Dimensions	85		
REC-12 Electric Driver	87		
REC-20 Battery Driver	88		
Recoil Installation Tooling			
Recoil Tanged / Tangless Hex Installation Tool	89		
Recoil Hex Electric Tool Part Numbers -			
Tanged and Tangless	90 Recoil		
Tangless Round Installation Tool	91 Recoil Prewinder		
Installation Tools	92		
Recoil Prewinder Hand Tool Part Numbers - Tanged and			
Tangless	93		
Recoil Tang Break Tool	95		
Recoil Removal Tool	96		

Introduction

Arconic Fastening Systems Recoil® brand manufacturing operations are located in Australia, with sales and warehouse facilities strategically located in North America, Asia, and Europe. Extensive worldwide distribution, coupled with the company's manufacturing strategy, offers significant advantages to end users.

Arconic Fastening Systems ensures a global consistency of quality design standards in manufacturing the full range of wire thread inserts in one production facility. Users around the world can be assured of high standards and the consistency of all our products.

Inserts are manufactured in standard sizes for all metric and inch thread forms. A comprehensive design facility is available to ensure that non-standard inserts can be manufactured for special part requirements.

Prompt availability of products to customers worldwide is ensured by an efficient international freight service and a network of stocking distributors. Arconic Fastening Systems is committed to the highest quality products and operating systems and employs a strict quality management system in accordance with:

- **AS9100** accreditation
- **ISO9001** accreditation
- **TS16949** accreditation
- **ISO14001** Environmental Systems

Arconic Fastening Systems will provide technical assistance to production engineers so that optimum installation efficiency can be achieved and maintained. Recoil brand coils are available to the following international and customer standards:

- NASM122076 Series - Free Running - UNC
- NASM124651 Series - Free Running - UNF
- NASM21209 Series – Locking UNC and UNF
- NASM8846
- BS7751 - Metric - Coarse
- BS7752 - Metric - Fine
- BS7753
- BS4377
- MA3279, MA3280, MA3281 - Metric - Free Running
- MA3329, MA3330, MA3331 - Metric - Self Locking
- AS6733 Series - UNF - Unplated
- AS8455 Series - UNF - Cadmium Plated
- NAS1130 - Imperial Tangless®
- NA0276 - Metric Tangless®
- AGS3700 Series - Nimonic Alloy 90 - Self Locking
- General Electric - N926 Series, N913
- LN9499, LN9039
- DIN8140
- BACI12AE - Boeing

Recoil® Range

The Recoil system consists of precision inserts, quality high speed taps, and easy-to-use installation tools which are used for repairing damaged screw threads or creating strong new threads. Recoil helically wound screw-thread inserts are generally manufactured from Type 304 (18-8) stainless steel wire cold rolled into a diamond shaped cross section. Recoil inserts can be supplied in other materials such as Inconel X750, Inconel 625, Nimonic 90, Nitronic 60, Phosphor Bronze and Type 316 stainless steel.

Recoil inserts are available in either standard free running form or screw lock type which provides an internal locking feature. Inserts are manufactured for every thread form including UNC, UNF, BSC, BSW, BSF, BA, BSP, NPT and ISO Metric thread sizes. Inserts are available in 5 different standard lengths. 1D, 1.5D, 2D, 2.5D and 3D. Special lengths are available on request.

Thread Repair Kits

A full range of Recoil thread repair kits, covering the majority of sizes commonly in use today is available. Recoil kits contain an HSS tap, installation tools, tang break tools, drills, stainless steel inserts, and instructions, in a sturdy reusable container. Recoil problem-solving repair kits are available in single or multiple size format.

Installation Tooling

Arconic Fastening Systems also offers a selection of work arms and power tooling, including high efficiency pneumatic and electric installation tools for in-line production or repetitive maintenance situations. A range of associated tooling is available to facilitate insert installation, including manual installation tooling and manual, spring and pneumatic operated tang breakoff tools.

Taps and Gauges

Optimum results can be achieved with Recoil taps and gauges to suit hand-tapping through to volume production requirements. Using the “Go - NoGo” gauge, tapped holes can be gauged to enable a precision fit.



How a Recoil® Insert Works

Recoil inserts are formed from high quality stainless steel wire with a diamond shaped cross section, wound to the shape of a spring thread. Once the wire is wound into a helical coil and installed into a tapped hole, it provides a permanent and wear resistant thread in the parent material that is generally stronger than the original thread. The inserts are designed to be greater in diameter than the tapped hole and compress as they are installed. This allows maximum surface contact area with the tapped thread, safely and permanently anchoring the inserts into place. The insert's compensatory action shares the load over the entire bolt and hole, increasing pull out and torque out strength. With a Recoil insert in place, load and stress are more evenly distributed over the assembly.

Where to Use Recoil Inserts

Original Equipment Manufacture

Arconic Fastening Systems offers innovative manufacturers the opportunity to design high quality product using lighter weight materials such as aluminum and magnesium alloys while still achieving high strength and reliability in the threaded fastener assembly. Recoil brand inserts are widely used by manufacturers in:

- Automotive
- Industrial Electronics
- Consumer Electronics
- Aerospace – Avionics, Engines, Airframe
- Ship Building
- Defense
- Power Generation
- Transport
- Manufacturing Equipment

Repair

When you encounter a damaged thread Recoil offers:

- Quickest and simplest method of repair to stripped or damaged threads
- A superior thread with great holding power
- Most cost-effective method of repair
- Returns thread to the original size
- Generally stronger than the original female thread

Insert Material

Recoil inserts are generally manufactured from Type 304 stainless steel (18-8), however inserts are available in a range of materials for special applications:

- Stainless Steel Grade 304 (AS7245) Austenitic Corrosion Resistant Steel For normal applications. Temperatures ranging from -195°C – 425°C (-320°F – 800°F)
- Stainless Steel Grade 316 (AISI316) Austenitic Corrosion Resistant Steel For Marine applications up to 425°C (800°F)
- Inconel X-750 (AS7246) Nickel Alloy. For high temperature applications 425°C - 550°C (800°F - 1020°F) or where low permeability is required.
- Phosphor Bronze (DIN17677 or BS2783 PB 102) (300°C) For electrical bonding joints or low permeability
- Nimonic 90 (HR503) for high temperature applications. (650°C/1200°F)
- Nitronic 60 (UNS S21800) Austenitic antigalling alloy

Special Purpose

- Materials such as Inconel 625 and Spring Steel Grade are also available to special order

Type

There are two basic types of Recoil inserts available:

- Free running inserts which provide a standard female thread
- Locking inserts which provide a locking function for the female thread when the fasteners installed

How a Recoil® Insert Works

Insert installation and retention

Uninstalled, Recoil inserts are greater in diameter than the tapped hole in the parent material into which they are to be installed. During the assembly operation the diameter of the leading coil is reduced thereby permitting entry of the insert into the tapped hole. When the insert is installed at the correct depth, the coils expand and permanently retains the insert in place. Unlike many 'solid' insert types, it is not necessary to use locking, swaging or keying operations to locate and retain Recoil inserts. Stress concentration problems which typically occur in the parent material when using solid inserts are therefore eliminated. A Recoil insert will dimensionally adjust both radially and axially, to any expansion or contraction within the parent material.

Typical thread and angle errors may cause:

- Limited contact point
- Poor flank contact between bolt to parent thread
- Unequal distribution of bolt load over engaged threads
- Failure of threaded components when loaded

Recoil inserts reduce thread pitch and angle errors to provide:

- Greater fastener strength
- Greater contact area
- Equally distributed load over all tapped threads
- Reduced stress concentration thereby extending fatigue life



Recoil insert in semi-installed position



Angle error



Pitch error

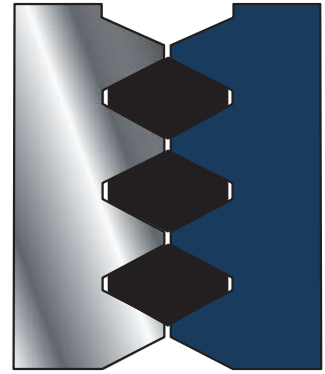

Recoil compensation effect

How a Recoil® Insert Works



1. DRILL

Drill to clear out the damaged thread with drill size as specified on kit (if necessary).

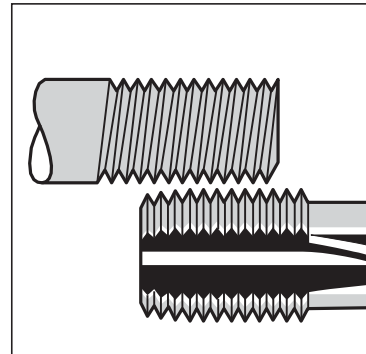

2. CHECK:

Ensure tap thread matches bolt.

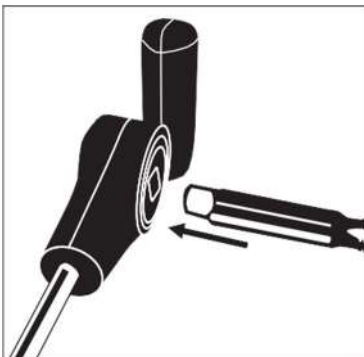

3. TAP:

Place tap into tap wrench or use the square drive in the installation tool if provided. (Square drive tool only suitable for tapping non-ferrous alloys.)



3a. TAP HOLE:

Tap hole to the required depth using correct procedures (if unsure contact your dealer).

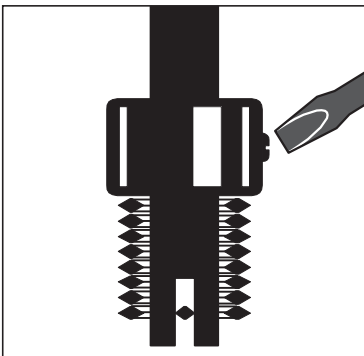

4. SET TOOL:

Place insert on installation tool, positioning the adjustable top so that the insert tang is centered in the tang slot.

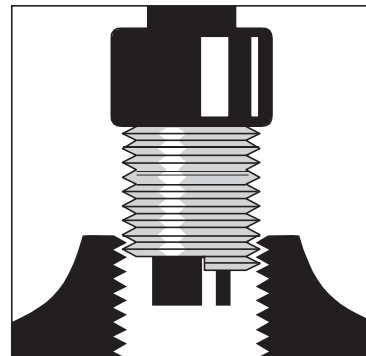

5. INSTALL:

Wind insert in with light downward pressure until 1/4 to 1/2 turn below the surface.

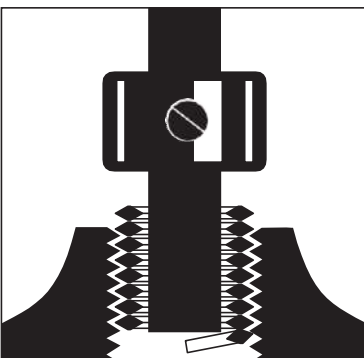

6. TANG REMOVAL:

Do not attempt to twist tang off with tool. Lift tool from tang, turn tool 90° and tap down sharply. Use Tang Break Tool where supplied. For sparkplug and large fine thread inserts, use long nose pliers to pull tang out.

How a Recoil® Insert Works

The diagram below depicts graphically the advantages a Recoil insert has over a conventional thread. In conventional threaded joints over 75% of the load is placed on the first three threads of the assembly. The Recoil insert on the left shows how the spring-like design of the insert allows the shear loading to be transformed into a preferable “hoop stress” or radial loading over the entire length of the insert. This provides a much stronger thread than can be obtained by conventional drilling or tapping.

This improved strength allows designers to select a fastener based on the minimum strength of the bolt, also allowing them to select smaller diameters and shorter thread lengths confidently even in low strength materials such as magnesium or aluminium alloys. (Refer to page 102 - Design Considerations)

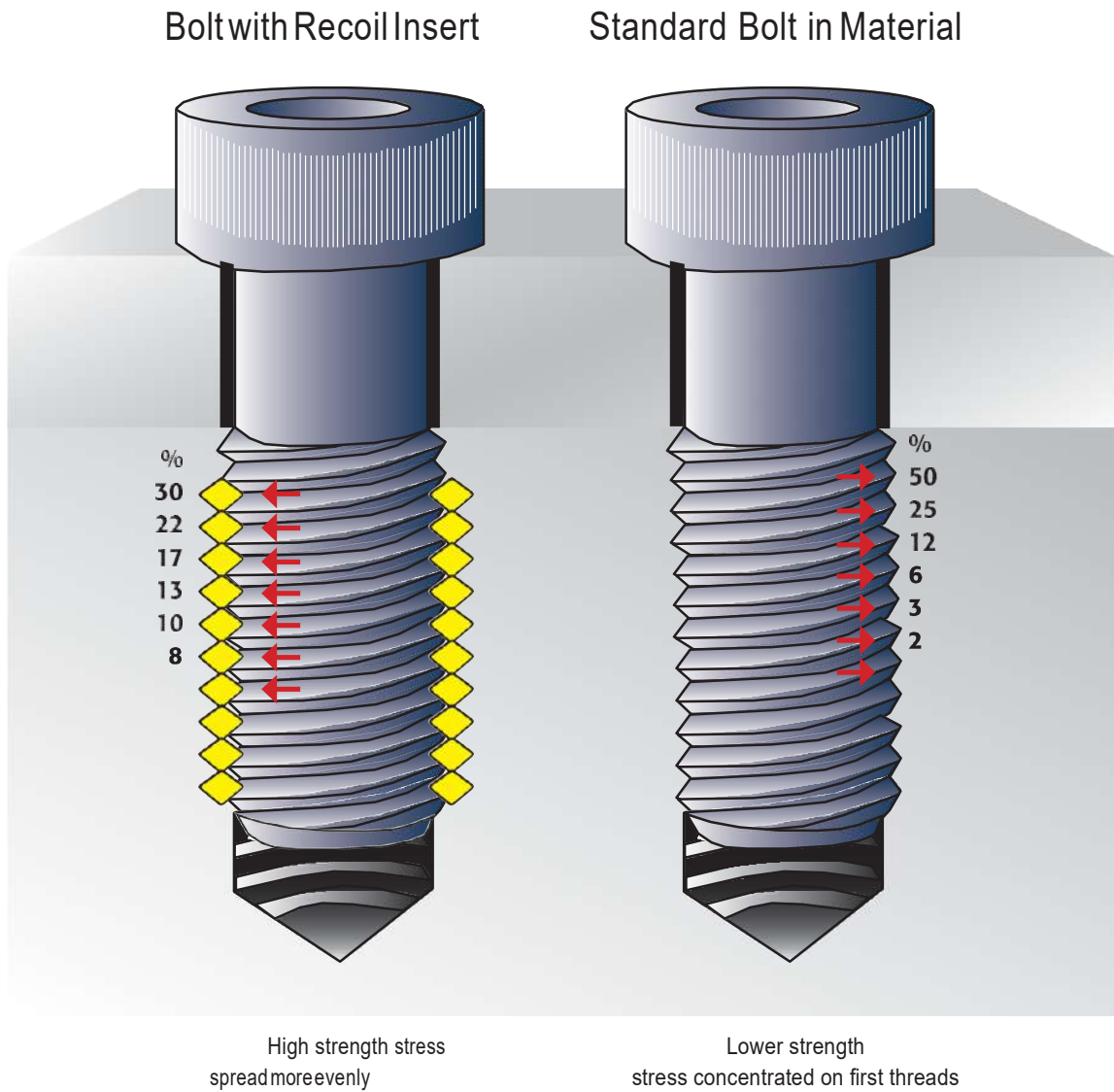

How a Locking Insert Works

The Recoil® screw-locking insert is designed to provide a screw- locking feature which will retain screws or bolts under the most severe vibration or varying temperature conditions. The insert locking configuration comprises a series of uniquely designed locking chords which, upon the engagement of a screw or bolt, deflect radially to permit the installation of the bolt. Upon bolt entry, these straight segments are flexed outwardly, creating pressure on the bolt. This pressure is applied between the flanks of the bolt thread so that contact area is maximized. Locking inserts retain locking torque over numerous assembly cycles. Refer to relevant specifications for insert life. Each Recoil screw-locking insert type has a specifically designed locking configuration. This ensures that the insert meets its design specification requirements. Therefore the shape, depth, and number of locking chords will inevitably vary for differing thread types and sizes.

Note: It is recommended that a cadmium plated or dry-film lubricated screw/bolt is used for screw-locking inserts applications. (See Lubricants and Coatings page).

Note: Refer to page 40 for locking torque values

Locking Insert Design

Should a specific locking torque or function be required, Arconic Fastening Systems engineers can develop parts to suit customers' needs. As the bolt is wound through the locking chords of the insert it deflects the wire as shown by the internal arrows (A). This deflection causes the insert to push against the bolt resulting in a repeatable locking function from the insert.

Note: Installation of Recoil screw-locking inserts requires use of the Recoil Prewinder tooling.

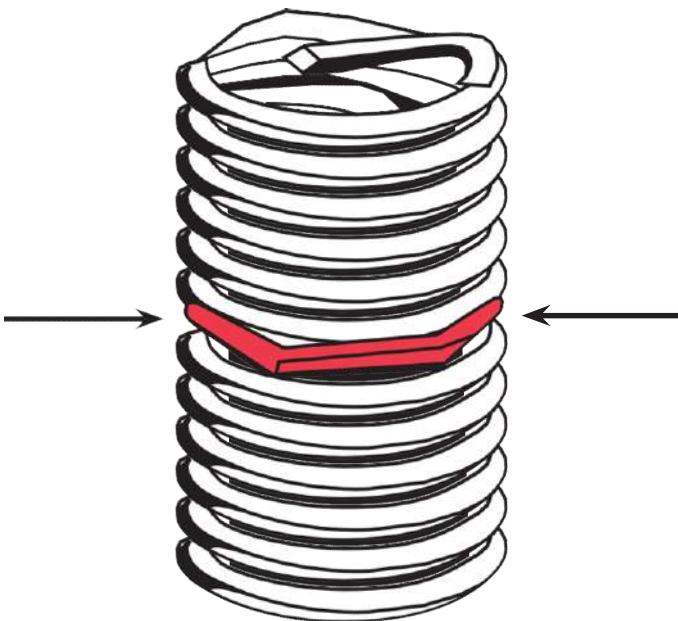
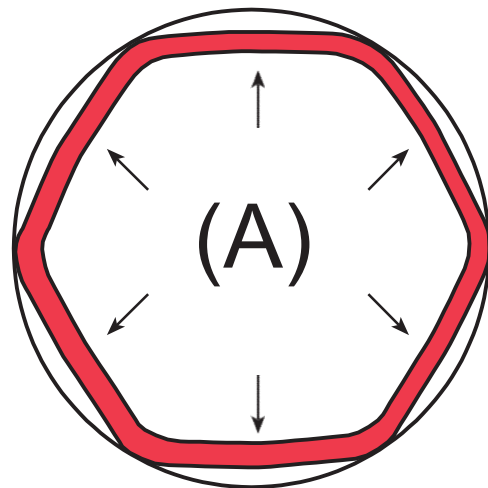

Recoil® Tangless® Inserts

Save time and reliably meet a wide range of installation challenges with Recoil Tangless Inserts. These advanced inserts offer all of the strength and easy installation characteristics of standard Recoil wire thread inserts, but with a big plus: no tang to break off post- installation. Like standard Recoil thread inserts, once installed, these Tangless designs share the load over the entire bolt and hole, improving joint strength and pull-out resistance.

Increased Installation Speed

- No tang to break off post-insert installation, eliminating a stage in the installation process; ideal for automatic installation in high volume applications
- No tang to retrieve post-insert installation, eliminating the requirement for vacuuming or extraction (and counting displaced tangs)
- Bi-directional design eliminates insert orientation, eliminating the need for time-consuming insert checking prior to each installation

Installation Adjustment and Removal Flexibility

- Tangless inserts are easily adjusted or removed after initial installation; just re-insert the installation tool, then wind or insert the removal tool, and unwind the insert
- Tangless inserts removal tools never touch the application, ensuring no damage occurs; an improvement over outmoded insert removal techniques

Foreign Object Debris (FOD)– Free

- Eliminating loose tang that can potentially damage the finished product.

Combined with all the benefits of standard Recoil wire thread inserts

Wire thread inserts strengthen threads, giving applications a longer life. Each insert shares the load over the entire bolt and hole, improving holding or pull-out resistance. With a Recoil insert installed, a more even distribution of load and stress is achieved.

Note: Tangless® is a registered trademark of Advanex Inc.



Materials and Coatings

It is important that correct selection of the most suitable fastening lubricant or coating is made at the design stage for long term security within the bolted joint. The ideal finish or coating for the insert is dependent upon the optimum coefficient of friction (governed by the bolt material and surface finish) and the required service conditions of the assembled parts, e.g. temperature, chemical influences, humidity, and dust. The coefficient of friction (μ) of most threaded components will generally vary between $\mu = 0.15$

and $\mu = 0.35$. For example differences occur between bolts made of Grade 8.8 steel (Werkstoff 1.0503), compared with the same size of bolt produced from an austenitic stainless steel X5 CrNi 18-9, (Werkstoff 1.4301). Differences also occur between bolts having different surface coatings, such as electro-galvanizing, hot galvanizing, cadmium plating, or chromium plating.

MATERIAL TYPE	MAX. TEMPERATURE		TYPICAL APPLICATIONS (SEE SECTION ON LUBRICANTS)	COATINGS
	PEAK	CONTINUOUS		
Stainless 304	425°C (800°F)	315°C (600°F)	Most general applications in all materials	Non-finished Dry film lubricant Silver Cadmium Zinc Nickel
Stainless 316 (Y)	425°C (800°F)	315°C (600°F)	Improved corrosion resistance Salt water applications	Non-finished Dry film lubricant Silver Cadmium Zinc Nickel
Nitronic 60 (T)	425°C (800°F)	315°C (600°F)	Anti-galling	Dry film lubricant
Phosphor Bronze (P)	300°C (572°F)	235°C (455°F)	Copper parts Non magnetic / Low permeability applications	Cadmium Silver
Inconel X-750 (X)	650°C (1200°F)	550°C (1020°F)	Aerospace / Turbines / Corrosive Atmospheres / High temperature use	Silver Copper
Nimonic 90 (N)	650°C (1200°F)	550°C (1020°F)	Aerospace / Turbine applications	Silver

Materials

304 Stainless (Standard)

Most general applications in all materials. Manufactured to AS7245



304 Stainless (Standard)

316 Stainless (Y)

Often used in highly corrosive applications, Recoil® 316 Stainless Steel inserts provide a high degree of reliable corrosion resistance. In freshwater, saltwater, even chlorine environments, the inserts are designed to deliver years of failure-proof threadholding performance.



316 Stainless (Y)

Phosphor Bronze (P)

Designed for electrical applications, Recoil Phosphor Bronze inserts provide no outside interference of signals. This characteristic ensures their successful use in electrical bonding joints and related operations. These advanced inserts have been successfully employed in the manufacturing of a wide range of sensitive electrical equipment including circuit boards, telecommunications control boxes, and medical instrumentation and equipment.



Phosphor Bronze (P)

Inconel (X)

Inconel X-750 is an alloy material with excellent high heat resistance and strength characteristics. Used in demanding applications like gas turbines and auto lambda sensor repairs, these inserts can withstand temperatures of 1020°F and can be certified to GE Power Generation standards. Inconel X-625 material possesses very high corrosion resistance and is used in sub-sea platforms and other critical salt water and marine applications.



Unplated



Nitronic 60 Inserts (N)

Designed for applications where galling can be a problem, Recoil Nitronic 60 inserts' wear-resistant, anti-galling characteristics eliminate the need for additional lubrication. Based on the reduction in friction they provide, these inserts deliver more consistent clamping torque. In addition, Nitronic 60 inserts are suitable for use with stainless steel screws.



Nitronic 60 Inserts (N)

Finishes and Coatings

Silver Plating (AG)

Primarily used to reduce the effects of galling (seizure) of screw threads in high temperature service applications. Silver plating is the most commonly used coating for aero-engine fasteners providing an even degree of lubrication up to a maximum service temperature of about 650°C (1200°F). The plated silver is electrolytically deposited in typical thicknesses up to 6.3µm (0.00025"). Silver plated wire thread inserts may be installed into various housing materials including magnesium alloys, aluminum alloys, corrosion and heat resistant materials, etc.

Caution must be emphasized where inserts are to be installed into titanium alloy components which may exceed a service temperature of 300°C (570°F). Silver plated inserts are not recommended with titanium housings as stress corrosion, resulting from the combination of silver with titanium may occur in the housing material. As per DTD939.



SilverPlating(AG)

Tin Plating(SN)

As per ISO2093, used for moderate corrosive condition typically in automotive applications



Tin Plating (SN)

Red Dye Coating

Recoil® screw-locking inserts are, generally color coded with a red dye coating for identification purposes only. This organic resin based dye does not affect the installation or function of the inserts and normally does not need to be removed. However, if in extreme conditions of cleanliness (such as precision instrument assembly in clean room conditions) removal of the dye may be desired. The red dye may be removed by soaking the inserts in a denatured alcohol solution prior to use. To prevent galling or seizing when using an unplated or corrosion resistant screw/bolt in a screw-locking insert, we recommend the use of an anti-seize compound on the bolt threads.



Red Dye Coating

Dry Film Lubricants (D)

Used for mildly corrosive or high temperature applications, dry film lubricants comprise suspensions of small particles of solid lubricants such as molybdenum disulphide (MoS₂) or PTFE, in organic or inorganic binders. They are applied as a thin film (5µm - 20µm) to grease-free metal surfaces. Through careful selection of appropriate additives and solvents, specific lubricants may be formulated to suit most industrial applications to service temperatures around 315°C (600°F). Special high temperature lubricant coatings are available for use up to 425°C (800°F). Recoil inserts may be coated with dry film lubricant in either the non-finished (passivated) condition or after cadmium plating treatment for maximum corrosion protection. As per AS5272.



Dry Film Lubricants (D)

Finishes and Coatings

Cadmium Plating (C)

In mildly corrosive or marine environments, cadmium plating is the preferred treatment for providing protection against pitting of the insert/bolt materials and to minimize the risk of thread seizure. Plating thickness may vary depending on particular applications, between 2µm - 5µm (0.0001" - 0.0002"). Following cadmium plating, either a bronze or olive drab chromate finish will be used to provide uniformity in the overall finish. It should be noted that cadmium plated parts must not:

- Be subjected to temperatures exceeding 235°C (455°F)
- Come into contact with fuel or hot oil
- Come into contact with food or drinking water
- Be used with titanium components either directly or indirectly as, at elevated temperatures, embrittlement and subsequent component failure may occur
- As per QQP-416 or DEF STD 03-19.

Warning: Cadmium is a highly toxic compound. Because of its poisonous nature extreme care must be taken when handling.



Free Running Inserts
Gold to Yellow Chromate

Cadmium Plating (C)
Locking Insert
Olive Drab to
Dark Brown Chromate

Zinc Nickel Coating

Zinc-Nickel electroplating is an alloy coating and is an environmentally safe alternative to cadmium electroplating.

Zinc-Nickel demonstrates equivalent, or better, corrosion properties when compared to cadmium and is normally applied for corrosion purposes and functions as a "sacrificial coating", corroding before the base material. Zinc-Nickel is an efficient economical coating, with minimal environmental impact and is typically applied at 2.5µm thickness on wire thread inserts.

Salt Spray Corrosion Tests are carried out (at least 1000 hours until red corrosion). RoHS Compliant and has been applied to meet the requirements of AMS 2417



Zinc Nickel Coating
Dyed

Zinc Nickel Coating
Undyed

Blue and Green Dye Coating

This organic resin based dye does not affect the installation or function of the inserts and normally does not need to be removed. However, if in extreme conditions of cleanliness (such as precision instrument assembly in clean room conditions) removal of the dye may be desired. The red dye may be removed by soaking the inserts in a denatured alcohol solution prior to use. To prevent galling or seizing when using an unplated or corrosion resistant screw/bolt in a screw-locking insert, we recommend the use of an anti-seize compound on the bolt threads.

Note: Recoil® inserts Green or Blue for identification purposes.



Blue and Green Dye Coating

Corrosion Protection

Under some service conditions, Recoil® inserts and their mating parts may be subjected to a degree of corrosion, the severity of which is dependent upon the particular application. Factors such as differing material types, atmospheric conditions, chemical attack, and even frequency of use will have an appreciable effect on the longevity of the bolted joint.

The following are recommendations to minimize corrosion within the bolted Recoil insert assemblies. Normal Service: Natural atmospheric environment with the screw/bolt permanently installed into the insert not adjacent to salt water.

Normal Service:

Natural atmospheric environment with the screw/bolt permanently installed into the insert not adjacent to salt water.

Severe Service:

Mildly contaminated atmospheric environments involving moisture, occasional exposure to a chloride air or sea spray, and where the screw/bolt may be removed from the insert for extended periods of time.

Extreme Severe Service:

Assembly is exposed to salt water, corrosive atmosphere, high temperature, or the screw/bolt is frequently removed from the assembly, allowing the ingress of water into a blind hole. In addition to methods 1, 2 and 3 below, further corrosion protection can be achieved by:

- Using blind holes wherever possible
- Using a sealing, insulating, or step-down type washer under the head of the bolt
- Using bolts that extend completely through the entire length of the insert
- In critical applications, the use of a non-hardening seal or compound over the joint and protecting bolt thread is recommended

Note - For extremely severe service conditions involving temperatures in excess of 425°C (800°F) or contact with acids, alkalis or sea water, stainless steel inserts are not recommended.

Gas and Water Applications

Where gas or water threads are being manufactured or repaired it is important that an Arconic Fastening Systems sales office be consulted regarding the type of seal that will be provided in this situation. A wire insert may not provide a satisfactory thread seal.

SERVICE CONDITIONS			
PARENT MATERIAL	NORMAL	SEVERE	EXTREME SEVERE
Aluminum	None	Methods 2 or 3	Methods 1, 2 & 3
Magnesium	Methods 2 or 3	Methods 2 or 3	Methods 1, 2 & 3

TYPICAL CORROSION RECOMMENDATIONS		
METHOD 1	METHOD 2	METHOD 3
Parent Material Protection Aluminum: For oxide coating use Alodine, Anodize, Iridite, or similar. Iridite 14 or 14-2 (MIL-C-554) is recommended for critical parts rather than anodizing (MIL-S-5002).	Coat the insert with one of the following: Cadmium per QQ-P-416, Type II 0.0001" thick; or Dry Film Lubricant per MIL- L- 893 (must be free of graphite) and Zinc Nickel.	Separate the parent material from the insert by using liquid zinc chromate primer, Federal Specification TT-P-1757. Apply the primer to the hole sparingly and install while the primer is still wet.

Recoil® Tapped Hole Dimensions - Standard

Recoil Tapped Hole Dimensions - Metric

Thread Size	Basic Length of Insert in Terms of Nominal Diameter of Screw "D"																			
	1D				1.5D				2D				2.5D				3D			
	Q	R	S	T	Q	R	S	T	Q	R	S	T	Q	R	S	T	Q	R	S	T
M2 - 0.4	2.00	1.60	3.80	3.40	3.00	2.60	4.80	4.40	4.00	3.60	5.80	5.40	5.00	4.60	6.80	6.40	6.00	5.60	7.80	7.40
M2.2 - 0.45	2.20	1.75	4.23	3.98	3.30	2.85	5.33	4.88	4.40	3.95	6.43	5.98	5.50	5.05	7.53	7.08	6.60	6.15	8.63	8.18
M2.5 - 0.45	2.50	2.05	4.53	4.08	3.75	3.30	5.78	5.33	5.00	4.55	7.03	6.58	6.25	5.80	8.28	7.83	7.50	7.05	9.53	9.08
M3 - 0.5	3.00	2.50	5.25	4.75	4.50	4.00	6.75	6.25	6.00	5.50	8.25	7.75	7.50	7.00	9.75	9.25	9.00	8.50	11.25	10.75
M3.5 - 0.6	3.50	2.90	6.20	5.60	5.25	4.65	7.95	7.35	7.00	6.40	9.70	9.10	8.75	8.15	11.45	10.85	10.50	9.90	13.20	12.60
M4 - 0.7	4.00	3.30	7.15	6.45	6.00	5.30	9.15	8.45	8.00	7.30	11.15	10.45	10.00	9.30	13.15	12.45	12.00	11.30	15.15	14.45
M4.5 - 0.75	4.50	3.75	7.88	7.13	6.75	6.00	10.13	9.38	9.00	8.25	12.38	11.63	11.25	10.50	14.63	13.88	13.50	12.75	16.88	16.13
M5 - 0.8	5.00	4.20	8.60	7.80	7.50	6.70	11.10	10.30	10.00	9.20	13.60	12.80	12.50	11.70	16.10	15.30	15.00	14.20	18.60	17.80
M6 - 1	6.00	5.00	10.50	9.50	9.00	8.00	13.50	12.50	12.00	11.00	16.50	15.50	15.00	14.00	19.50	18.50	18.00	17.00	22.50	21.50
M7 - 1	7.00	6.00	11.50	10.50	10.50	9.50	15.00	14.00	14.00	13.00	18.50	17.50	17.50	16.50	22.00	21.00	21.00	20.00	25.50	24.50
M8 - 1	8.00	7.00	12.50	11.50	12.00	11.00	16.50	15.50	16.00	15.00	20.50	19.50	20.00	19.00	24.50	23.50	24.00	23.00	28.50	27.50
M8 - 1.25	8.00	6.75	13.63	12.38	12.00	10.75	17.63	16.38	16.00	14.75	21.63	20.38	20.00	18.75	25.63	24.38	24.00	22.75	29.63	28.38
M9 - 1.25	9.00	7.75	14.63	13.38	13.50	12.25	19.13	17.88	18.00	16.75	23.63	22.38	22.50	21.25	28.13	26.88	27.00	25.75	32.63	31.38
M10 - 1.25	10.00	8.75	15.63	14.38	15.00	13.75	20.63	19.38	20.00	18.75	25.63	24.38	25.00	23.75	30.63	29.38	30.00	28.75	35.63	34.38
M10 - 1.5	10.00	8.50	16.75	15.25	15.00	13.50	21.75	20.25	20.00	18.50	26.75	25.25	25.00	23.50	31.75	30.25	30.00	28.50	36.75	35.25
M11 - 1.5	11.00	9.50	17.75	16.25	16.50	15.00	23.25	21.75	22.00	20.50	28.75	27.25	27.50	26.00	34.25	32.75	33.00	31.50	39.75	38.25
M12 - 1.25	12.00	10.75	17.63	16.38	18.00	16.75	23.63	22.38	24.00	22.75	29.63	27.38	30.00	28.75	35.63	34.38	36.00	34.75	41.63	40.38
M12 - 1.5	12.00	10.50	18.75	17.25	18.00	16.50	24.75	23.25	24.00	22.50	30.75	29.25	30.00	28.50	36.75	32.25	36.00	34.50	42.75	41.25
M12 - 1.75	12.00	10.25	19.88	18.13	18.00	16.25	25.88	24.13	24.00	22.25	31.88	30.13	30.00	28.25	37.88	36.13	36.00	34.25	43.88	42.13
M14 - 1.5	14.00	12.50	20.75	19.25	21.00	19.50	27.75	26.25	28.00	26.50	34.75	33.25	35.00	33.50	41.75	40.25	42.00	40.50	48.75	47.25
M14 - 2	14.00	12.00	23.00	21.00	21.00	19.00	30.00	28.00	28.00	26.00	37.00	35.00	35.00	33.00	44.00	42.00	42.00	40.00	51.00	49.00
M16 - 1.5	16.00	14.50	22.75	21.25	24.00	22.50	30.75	29.25	32.00	30.50	38.75	37.25	40.00	38.50	46.75	45.25	48.00	46.50	54.75	53.25
M16 - 2	16.00	14.00	25.00	23.00	24.00	22.00	33.00	31.00	32.00	30.00	41.00	39.00	40.00	38.00	49.00	47.00	48.00	46.00	57.00	55.00
M18 - 1.5	18.00	16.50	24.75	23.25	27.00	25.50	33.75	32.25	36.00	34.50	42.75	41.25	45.00	43.50	51.75	50.25	54.00	52.50	60.75	59.25
M18 - 2	18.00	16.00	27.00	25.00	27.00	25.00	36.00	34.00	36.00	34.00	45.00	43.00	45.00	43.00	54.00	52.00	54.00	52.00	63.00	61.00
M18 - 2.5	18.00	15.50	29.25	26.75	27.00	24.50	38.25	35.75	36.00	33.50	47.25	44.75	45.00	42.50	56.25	53.75	54.00	51.50	65.25	62.75
M20 - 1.5	20.00	18.50	26.75	25.25	30.00	28.50	36.75	35.25	40.00	38.50	46.75	45.25	50.00	48.50	56.75	55.25	60.00	58.50	66.75	65.25
M20 - 2	20.00	18.00	29.00	27.00	30.00	28.00	39.00	37.00	40.00	38.00	49.00	47.00	50.00	48.00	59.00	57.00	60.00	58.00	69.00	67.00
M20 - 2.5	20.00	17.50	31.25	28.75	30.00	27.50	41.25	38.75	40.00	37.50	51.25	48.75	50.00	47.50	61.25	58.75	60.00	57.50	71.25	68.75

Recoil® Tapped Hole Dimensions - Metric

Thread Size	Basic Length of Insert in Terms of Nominal Diameter of Screw "D"																			
	1D				1.5D				2D				2.5D				3D			
	Q	R	S	T	Q	R	S	T	Q	R	S	T	Q	R	S	T	Q	R	S	T
Metric																				
M22 - 1.5	22.00	20.50	28.75	27.25	33.00	31.50	39.75	38.25	44.00	42.50	50.75	49.25	55.00	53.50	61.75	60.25	66.00	64.50	72.75	71.25
M22 - 2	22.00	20.00	31.00	29.00	33.00	31.00	42.00	40.00	44.00	42.00	53.00	51.00	55.00	53.00	64.00	62.00	66.00	64.00	75.00	73.00
M22 - 2.5	22.00	19.50	33.25	30.75	33.00	30.50	44.25	41.75	44.00	41.50	55.25	52.75	55.00	52.50	66.25	63.75	66.00	63.50	77.25	74.75
M24 - 2	24.00	22.00	33.00	31.00	36.00	34.00	45.00	43.00	48.00	46.00	57.00	55.00	60.00	58.00	69.00	67.00	72.00	70.00	81.00	79.00
M24 - 3	24.00	21.00	37.50	34.50	36.00	33.00	49.50	46.50	48.00	45.00	61.50	58.50	60.00	57.00	73.50	70.50	72.00	69.00	85.50	82.50
M27 - 3	27.00	24.00	40.50	37.50	40.50	37.50	54.00	51.00	54.00	51.00	67.50	64.50	67.50	64.50	81.00	78.00	81.00	78.00	94.50	91.50
M30 - 3.5	30.00	26.50	45.75	42.25	45.00	41.50	60.75	57.25	60.00	56.50	75.75	72.25	75.00	71.50	90.75	87.25	90.00	86.50	105.75	102.25
M33 - 3.5	33.00	29.50	48.75	45.25	49.50	46.00	65.25	61.75	66.00	62.50	81.75	78.25	82.50	79.00	98.25	94.75	99.00	95.50	114.75	111.25
M36 - 4	36.00	32.00	54.00	50.00	54.00	50.00	72.00	68.00	72.00	68.00	90.00	86.00	90.00	86.00	108.00	104.00	108.00	104.00	126.00	122.00
M39 - 4	39.00	35.00	57.00	53.00	58.50	54.50	76.50	72.50	78.00	74.00	96.00	92.00	97.50	93.50	115.50	111.50	117.00	113.00	135.00	131.00

Drill Depth: The minimum drilling depth "S" allows for one pitch chip clearance between the tip of the tap and the bottom of the drilled hole. "S" minimum allows for tap clearance, the maximum amount of insert set-down and countersink. Where a spiral pointed tap is used, the drill depths shown should be increased to allow for chip clearance.

Fitted Insert:

R = Maximum length of engaged portion of screw when tang is removed.

Q = Minimum full tapped thread length.

T = Minimum tapping depth - including 3 1/2 threads of plug tap. S =

Minimum drill depth - excluding point.

Note: Recoil metric inserts are made to Din locking torque requirements. Military specification MA parts need to be specifically ordered by adding MA to the standard part number above.

Note: Dimensions shown are for MA parts only.

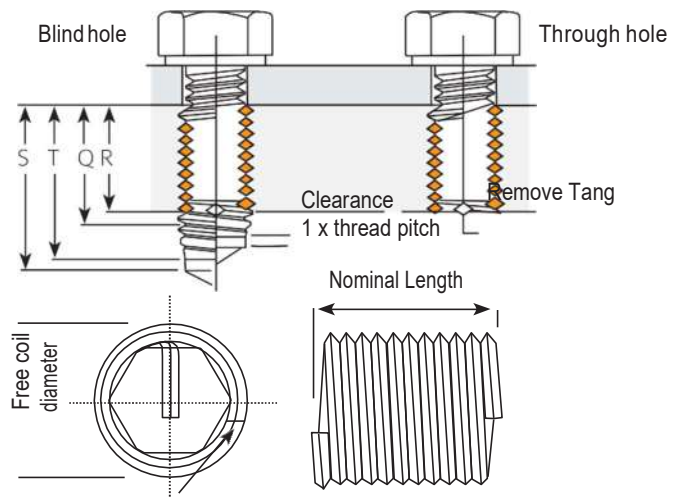

Recoil® Tapped Hole Dimensions - Unified Coarse

Thread Size	Basic Length of Insert in Terms of Nominal Diameter of Screw "D"																			
	1D			1.5D				2D			2.5D				3D					
	Q _S	R	T	Q	R	S	T	Q	R	T	Q	R	S	T	Q	R	S	T		
2(.086")-56	0.086	0.068	0.166	0.148	0.129	0.111	0.209	0.191	0.172	0.154	0.252	0.234	0.215	0.197	0.295	0.277	0.258	0.240	0.338	0.320
3(.099")-48	0.099	0.078	0.193	0.172	0.148	0.127	0.242	0.221	0.198	0.177	0.292	0.271	0.248	0.227	0.342	0.321	0.297	0.276	0.391	0.370
4(.112")-40	0.112	0.087	0.224	0.199	0.168	0.143	0.28	0.255	0.224	0.199	0.336	0.311	0.280	0.255	0.392	0.367	0.336	0.311	0.448	0.423
5(.125")-40	0.125	0.100	0.237	0.212	0.187	0.162	0.300	0.275	0.250	0.225	0.362	0.337	0.312	0.287	0.425	0.400	0.375	0.350	0.487	0.462
6(.138")-32	0.138	0.107	0.279	0.247	0.207	0.176	0.348	0.316	0.276	0.245	0.417	0.385	0.345	0.314	0.486	0.454	0.414	0.383	0.555	0.523
8(.164")-32	0.164	0.133	0.305	0.273	0.246	0.215	0.387	0.355	0.328	0.297	0.469	0.437	0.410	0.379	0.551	0.519	0.492	0.461	0.633	0.601
10(.190")-24	0.190	0.148	0.377	0.336	0.285	0.243	0.472	0.431	0.380	0.338	0.567	0.526	0.475	0.433	0.662	0.621	0.570	0.528	0.757	0.716
12(.216")-24	0.216	0.174	0.404	0.362	0.324	0.282	0.512	0.470	0.432	0.390	0.620	0.578	0.540	0.498	0.727	0.686	0.648	0.606	0.836	0.794
1/4(.2500")-20	0.250	0.200	0.475	0.425	0.375	0.325	0.600	0.550	0.500	0.450	0.725	0.675	0.625	0.575	0.850	0.800	0.750	0.700	0.975	0.925
5/16(.3125")-18	0.312	0.257	0.562	0.507	0.469	0.413	0.719	0.663	0.625	0.569	0.875	0.819	0.781	0.726	1.031	0.976	0.937	0.882	1.187	1.132
3/8(.3750")-18	0.375	0.312	0.656	0.594	0.562	0.500	0.844	0.781	0.750	0.687	1.031	0.969	0.937	0.875	1.219	1.156	1.125	1.062	1.406	1.344
7/16(.4375")-14	0.437	0.366	0.759	0.687	0.656	0.585	0.978	0.906	0.875	0.804	1.196	1.125	1.094	1.022	1.415	1.343	1.312	1.241	1.634	1.562
1/2(.5000")-13	0.500	0.423	0.846	0.769	0.750	0.673	1.096	1.019	1.000	0.923	1.346	1.269	1.250	1.173	1.596	1.519	1.500	1.423	1.846	1.769
9/16(.5625")-12	0.562	0.479	0.937	0.854	0.844	0.760	1.219	1.135	1.125	1.042	1.500	1.417	1.406	1.323	1.781	1.698	1.687	1.604	2.062	1.979
5/8(.6250")-11	0.625	0.534	1.034	0.943	0.937	0.846	1.347	1.256	1.250	1.159	1.659	1.568	1.562	1.471	1.972	1.881	1.875	1.784	2.284	2.193
3/4(.7500")-10	0.750	0.650	1.200	1.100	1.125	1.025	1.575	1.475	1.500	1.400	1.950	1.850	1.875	1.775	2.325	2.225	2.250	2.150	2.700	2.600
7/8(.8750")-9	0.875	0.764	1.375	1.264	1.312	1.201	1.812	1.701	1.750	1.639	2.250	2.139	2.187	2.076	2.687	2.576	2.625	2.514	3.125	3.014
1(1.000")-8	1.000	0.875	1.563	1.437	1.500	1.375	2.062	1.937	2.000	1.875	2.562	2.437	2.500	2.375	3.062	2.937	3.000	2.875	3.562	3.437
1 1/8(1.1250")-7	1.125	0.982	1.768	1.625	1.687	1.545	2.330	2.187	2.250	2.107	2.893	2.750	2.812	2.670	3.455	3.312	3.375	3.232	4.018	3.875
1 1/4(1.2500")-7	1.250	1.107	1.893	1.750	1.875	1.732	2.518	2.375	2.500	2.357	3.143	3.000	3.125	2.982	3.768	3.625	3.750	3.607	4.393	4.250
1 3/8(1.3750")-6	1.375	1.208	2.125	1.958	2.062	1.896	2.812	2.646	2.750	2.583	3.500	3.333	3.437	3.270	4.187	4.021	4.125	3.958	4.875	4.708
1 1/2(1.5000")-6	1.500	1.333	2.250	2.083	2.250	2.083	3.000	2.833	3.000	2.833	3.750	3.583	3.750	3.583	4.500	4.333	4.500	4.333	5.250	5.083

Drill Depth: The minimum drilling depth "S" allows for one pitch chip clearance between the tip of the tap and the bottom of the drilled hole. "S" minimum allows for tap clearance, the maximum amount of insert set-down and countersink. Where a spiral pointed tap is used, the drill depths shown should be increased to allow for chip clearance.

Fitted Insert:

- R = Maximum length of engaged portion of screw when tang is removed.
- Q = Minimum full tapped thread length.
- T = Minimum tapping depth - including 3 1/2 threads of plug tap. S = Minimum drill depth - excluding point.

Note: Recoil metric inserts are made to Din locking torque requirements. Military specification MA parts need to be specifically ordered by adding MA to the standard part number above.

Note: Dimensions shown are for MA parts only.

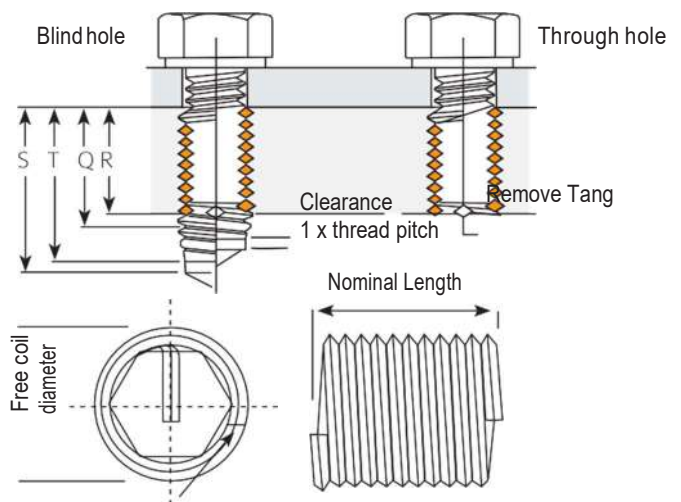

Recoil® Tapped Hole Dimensions - Unified Fine

Thread Size	Basic Length of Insert in Terms of Nominal Diameter of Screw "D"																			
	1D				1.5D				2D				2.5D				3D			
	Q	R	S	T	Q	R	S	T	Q	R	S	T	Q	R	S	T	Q	R	S	T
Unified Fine - Drill, Tapping and Installation Depths																				
#2 (.086") - 64	0.086	0.070	0.156	0.141	0.129	0.113	0.199	0.184	0.172	0.156	0.242	0.227	0.215	0.199	0.285	0.270	0.258	0.242	0.328	0.313
3 (.099") - 56	0.099	0.081	0.179	0.161	0.148	0.130	0.228	0.210	0.198	0.180	0.278	0.260	0.248	0.230	0.328	0.310	0.297	0.279	0.377	0.359
4 (.112") - 48	0.112	0.091	0.206	0.185	0.168	0.147	0.262	0.241	0.224	0.203	0.318	0.297	0.280	0.259	0.374	0.353	0.336	0.315	0.430	0.409
6 (.138") - 40	0.125	0.102	0.227	0.205	0.188	0.165	0.290	0.268	0.250	0.227	0.352	0.330	0.312	0.289	0.414	0.392	0.375	0.352	0.477	0.455
8 (.164") - 36	0.138	0.113	0.250	0.225	0.207	0.182	0.319	0.294	0.276	0.251	0.388	0.363	0.345	0.320	0.457	0.432	0.414	0.389	0.526	0.501
10 (.190") - 32	0.164	0.136	0.289	0.261	0.246	0.218	0.371	0.343	0.328	0.300	0.453	0.425	0.410	0.382	0.535	0.507	0.492	0.464	0.617	0.589
1/4 (.2500") - 28	0.190	0.159	0.331	0.299	0.285	0.254	0.426	0.394	0.380	0.349	0.521	0.489	0.475	0.444	0.616	0.584	0.570	0.539	0.711	0.679
5/16 (.3125")-24	0.250	0.214	0.411	0.375	0.375	0.339	0.536	0.500	0.500	0.464	0.661	0.625	0.625	0.589	0.786	0.750	0.750	0.714	0.911	0.875
3/8 (.3750") - 24	0.312	0.271	0.500	0.458	0.469	0.428	0.656	0.615	0.625	0.583	0.812	0.771	0.781	0.740	0.969	0.927	0.937	0.896	1.125	1.083
7/16 (.4375")-20	0.375	0.333	0.562	0.521	0.562	0.521	0.750	0.708	0.750	0.708	0.937	0.896	0.937	0.896	1.125	1.083	1.125	1.083	1.312	1.271
1/2 (.500") - 20	0.437	0.387	0.662	0.612	0.656	0.606	0.881	0.831	0.875	0.825	1.100	1.050	1.094	1.044	1.319	1.269	1.312	1.262	1.537	1.488
9/16 (.5625")-18	0.500	0.450	0.725	0.675	0.750	0.700	0.975	0.925	1.000	0.950	1.225	1.175	1.250	1.200	1.475	1.425	1.500	1.450	1.725	1.675
5/8 (.6250") - 18	0.562	0.507	0.812	0.757	0.844	0.788	1.094	1.038	1.125	1.068	1.375	1.319	1.406	1.351	1.656	1.601	1.687	1.632	1.937	1.882
3/4 (.7500") - 16	0.625	0.569	0.875	0.819	0.937	0.882	1.187	1.132	1.250	1.194	1.500	1.444	1.562	1.507	1.812	1.757	1.875	1.819	2.125	2.069
7/8 (.8750") - 14	0.750	0.687	1.031	0.969	1.125	1.062	1.406	1.344	1.500	1.437	1.781	1.719	1.875	1.812	2.156	2.094	2.250	2.187	2.531	2.469
1 (1.0000") - 14	0.875	0.804	1.196	1.125	1.312	1.241	1.634	1.562	1.750	1.679	2.071	2.000	2.187	2.116	2.509	2.437	2.625	2.554	2.946	2.875
1 (1.0000") - 12	1.000	0.917	1.375	1.292	1.500	1.417	1.875	1.792	2.000	1.917	2.375	2.292	2.500	2.417	2.875	2.792	3.000	2.917	3.375	3.292
1 1/8 (1.1250")-12	1.125	1.042	1.500	1.417	1.687	1.604	2.062	1.979	2.250	2.167	2.625	2.542	2.812	2.729	3.187	3.104	3.375	3.292	3.750	3.667
1 1/4 (1.2500")-12	1.250	1.167	1.625	1.542	1.875	1.792	2.250	2.167	2.500	2.417	2.875	2.792	3.125	3.042	3.500	3.417	3.750	3.667	4.125	4.042
1 3/8 (1.3750")-12	1.375	1.292	1.750	1.667	2.062	1.979	2.437	2.354	2.750	2.667	3.125	3.042	3.437	3.354	3.812	3.729	4.125	4.042	4.500	4.417
1 1/2 (1.5000")-12	1.500	1.417	1.875	1.792	2.250	2.167	2.625	2.542	3.000	2.917	3.375	3.292	3.750	3.667	4.125	4.042	4.500	4.417	4.875	4.792

Drill Depth: The minimum drilling depth "S" allows for one pitch chip clearance between the tip of the tap and the bottom of the drilled hole. "S" minimum allows for tap clearance, the maximum amount of insert set-down and countersink. Where a spiral pointed tap is used, the drill depths shown should be increased to allow for chip clearance.

Fitted Insert:

R = Maximum length of engaged portion of screw when tang is removed.

Q = Minimum full tapped thread length.

T = Minimum tapping depth - including 3 1/2 threads of plug tap. S =

Minimum drill depth - excluding point.

Note: Recoil metric inserts are made to Din locking torque requirements. Military specification MA parts need to be specifically ordered by adding MA to the standard part number above.

Note: Dimensions shown are for MA parts only.

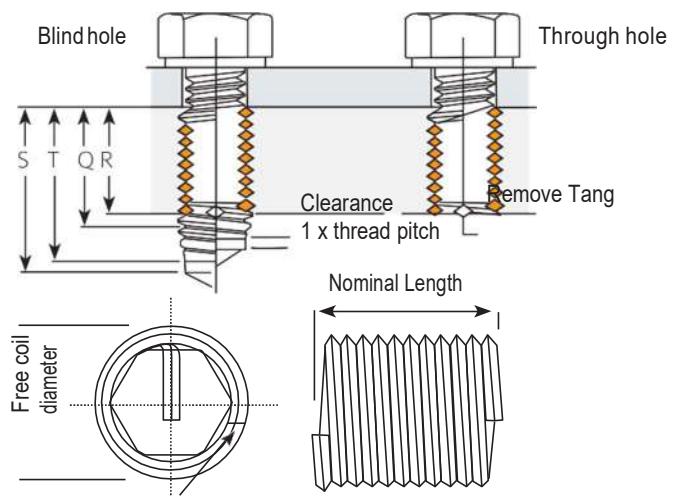



Recoil® Tapped Hole and Fitted Size Data - Metric Sizes Tanged and Tangless®

Thread Size	Drill Size	A		B	C	C		E	
		Minor Dia.	Major Dia.	Class 5H	Class 6H	Inserts Fitted			
Metric - Drill, Tapping and Installation Depths									
M2 - 0.4	2.10	2.177	2.087	2.520	2.295	2.260	2.310	2.260	1.567
M2.2-0.45	2.30	2.397	2.297	2.785	2.532	2.492	2.547	2.492	1.713
M2.5-0.45	2.60	2.697	2.597	3.085	2.832	2.792	2.847	2.792	2.013
M3 - 0.5	3.10	3.220	3.108	3.650	3.367	3.325	3.384	3.325	2.459
M3.5 - 0.6	3.60	3.755	3.630	4.279	3.940	3.890	3.959	3.890	2.850
M4 - 0.7	4.15	4.292	4.152	4.909	4.509	4.455	4.529	4.455	3.242
M5 - 0.8	5.20	5.333	5.173	6.039	5.577	5.520	5.597	5.520	4.134
M6 - 1.0	6.20	6.406	6.216	7.299	6.719	6.650	6.742	6.650	4.917
M7 - 1.0	7.20	7.406	7.216	8.299	7.719	7.650	7.742	7.650	5.917
M8 - 1.0	8.20	8.406	8.216	9.299	8.719	8.650	8.742	8.650	6.917
M8 - 1.25	8.30	8.483	8.271	9.624	8.886	8.812	8.912	8.812	6.647
M9 - 1.25	9.30	9.483	9.271	10.624	9.886	9.812	9.912	9.812	7.647
M10-1.25	10.30	10.483	10.271	11.624	10.886	10.812	10.912	10.812	8.647
M10 - 1.5	10.30	10.561	10.325	11.949	11.061	10.974	11.089	10.974	8.376
M11 - 1.5	11.30	11.561	11.325	12.949	12.061	11.974	12.089	11.974	9.376
M12-1.25	12.30	12.483	12.271	13.624	12.898	12.812	12.926	12.812	10.647
M12 - 1.5	12.50	12.56	13.324	14.131	12.974	13.067	12.974	13.099	10.376
M12-1.75	12.40	12.644	12.379	14.273	13.236	13.137	13.271	13.137	10.106
M14 - 1.5	14.30	14.561	14.325	15.949	15.067	14.974	15.099	14.974	12.376
M14 - 2.0	14.40	14.733	14.433	16.598	15.406	15.299	15.444	15.299	11.835
M16 - 1.5	16.25	16.561	16.325	17.949	17.067	16.974	17.099	16.974	14.376
M16 - 2.0	16.50	16.733	16.433	18.598	17.406	17.299	17.444	17.299	13.835
M18 - 1.5	18.25	18.561	18.325	19.949	19.067	18.974	19.099	18.974	16.376
M18 - 2.0	18.50	18.733	18.433	20.598	19.406	19.299	19.444	19.299	15.835
M18 - 2.5	18.50	18.896	18.541	21.248	19.738	19.624	19.778	19.624	15.294
M20 - 1.5	20.25	20.561	20.325	21.949	21.067	20.974	21.099	20.974	18.376
M20 - 2.0	20.50	20.733	20.433	22.598	21.406	21.299	21.444	21.299	17.835
M20 - 2.5	20.50	20.896	20.541	23.248	21.738	21.624	21.778	21.624	17.294
M22 - 1.5	22.50	22.561	22.325	23.949	23.067	22.974	23.099	22.974	20.376
M22 - 2.0	22.50	22.733	22.433	24.598	23.406	23.299	23.444	23.299	19.835
M22 - 2.5	22.50	22.896	22.541	25.248	23.738	23.624	23.778	23.624	19.294
M24 - 2.0	24.25	24.733	24.433	26.598	25.414	25.299	25.454	25.299	21.835
M24 - 3.0	24.75	25.050	24.650	27.897	26.093	25.949	26.135	25.949	20.752
M27 - 3.0	27.50	28.050	27.650	30.897	29.093	28.949	29.135	28.949	23.752
M30 - 3.5	30.50	31.208	30.758	34.547	32.428	32.273	32.472	32.273	26.211
M33 - 3.5	33.50	34.208	33.758	37.547	35.428	35.273	35.472	35.273	29.211
M36 - 4.0	36.50	37.341	36.866	41.196	38.763	38.598	38.809	38.598	31.670
M39 - 4.0	39.50	40.341	39.866	44.196	41.763	41.598	41.809	41.598	34.670

Recoil® Tapped Hole and Fitted Size Data - Unified Coarse Tanged and Tangless®

Thread Size	TPI	Drill Size		A	B	C	C	E			
		mm	Inch	Minor Dia.	Major Dia.	Class 2B	Class 3B	Inserts Fitted			
Unified Coarse - Drill, Tapping and Installation Depths											
2 (.086") - 56	56	2.3	3/32	0.0940	0.0900	0.1092	0.0996	0.0976	0.989	0.0976	0.0667
3 (.099") - 48	48	2.7	No.36	0.1080	0.1040	0.1261	0.1147	0.1125	0.1139	0.1125	0.0764
4 (.112") - 40	40	3.0	No.31	0.1220	0.1180	0.1445	0.1307	0.1282	0.1298	0.1282	0.0849
5 (.125") - 40	40	3.4	No.29	0.1350	0.1310	0.1575	0.1437	0.1412	0.1429	0.1412	0.0979
6 (.138") - 32	32	3.7	No.25	0.1500	0.1450	0.1786	0.1611	0.1583	0.1601	0.1583	0.1042
8 (.164") - 32	32	4.4	11/64	0.1750	0.1710	0.2046	0.1872	0.1843	0.1862	0.1843	0.1302
10 (.190") - 24	24	5.0	13/64	0.2050	0.1990	0.2441	0.2204	0.2171	0.2193	0.2171	0.1449
12 (.216") - 24	24	5.6	15/64	0.2300	0.2250	0.2701	0.2465	0.2431	0.2454	0.2431	0.1709
1/4 (.2500") - 20	20	6.7	17/64	0.2700	0.2610	0.3150	0.2863	0.2825	0.2851	0.2825	0.1959
5/16 (.3125") - 18	18	8.3	21/64	0.3340	0.3250	0.3847	0.3529	0.3486	0.3515	0.3486	0.2524
3/8 (.3750") - 18	16	9.9	25/64	0.3980	0.3890	0.4562	0.4203	0.4156	0.4189	0.4156	0.3073
7/16 (.4375") - 14	14	11.5	29/64	0.4630	0.4530	0.5303	0.4890	0.4839	0.4875	0.4839	0.3602
1/2 (.5000") - 13	13	13.0	17/32	0.5270	0.5170	0.5999	0.5554	0.5499	0.5537	0.5499	0.4167
9/16 (.5625") - 12	12	14.5	19/32	0.5910	0.5810	0.6708	0.6225	0.6167	0.6208	0.6167	0.4723
5/8 (.6250") - 11	11	16.5	21/32	0.6560	0.6450	0.7431	0.6903	0.6841	0.6885	0.6841	0.5266
3/4 (.7500") - 10	10	19.8	25/32	0.7830	0.7720	0.8799	0.8216	0.8149	0.8196	0.8149	0.6417
7/8 (.8750") - 9	9	23.0	29/32	0.9120	0.8990	1.0193	0.9543	0.9471	0.9522	0.9471	0.7547
1 (1.000") - 8	8	26.0	11/32	1.0420	1.0270	1.1624	1.0890	1.0812	1.0868	1.0812	0.8647
1 1/8 (1.1250") - 7	7	29.5	15/32	1.1700	1.1560	1.3106	1.2262	1.2178	1.2239	1.2178	0.9704
1 1/4 (1.250") - 7	7	33.0	19/32	1.2950	1.2810	1.4356	1.3514	1.3428	1.3490	1.3428	1.0954
1 3/8 (1.3750") - 6	6	36.0	113/32	1.4310	1.4110	1.5914	1.4926	1.4832	1.4900	1.4832	1.1946
1 1/2 (1.5000") - 6	6	39.0	117/32	1.5560	1.5360	1.7164	1.6177	1.6082	1.6151	1.6082	1.3196

Standard size drills are suggested even though in these sizes they vary slightly from minor diameter limits. Drill sizes are recommended only and test should be carried out to select the one suitable for the material involved.

Countersinking: It is recommended that a 120° countersink is provided before tapping to prevent a feather edge at the start of the lead thread. When design prevents the use of a countersink, any feather edges or deformed material at the thread lead should be removed before tapping. This will facilitate insert installation and reduce the effects of removing the countersinking operation.

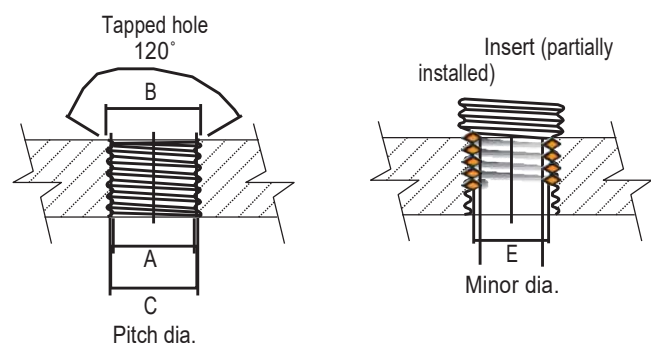

Recoil® Tapped Hole and Fitted Size Data - Unified Fine Tanged and Tangless®

Thread Size	TPI	Drill Size		A	B	C	C	E			
		mm	Inch	Minor Dia.	Major Dia.	Class 2B	Class 3B	Inserts Fitted			
Unified Fine - Drill, Tapping and Installation Depths											
3 (.099") - 56	56	2.65	-	0.1060	0.1030	0.1222	0.1126	0.1106	0.1119	0.1106	0.0797
4 (.112") - 48	48	3.0	No.31	0.1200	0.1170	0.1391	0.1278	0.1255	0.1270	0.1255	0.0894
6 (.138") - 40	44	3.3	-	0.1340	0.1300	0.1545	0.1422	0.1398	0.1414	0.1398	0.1004
8 (.164") - 36	40	3.7	No.26	0.1480	0.1440	0.1705	0.1568	0.1542	0.1559	0.1542	0.1109
10 (.190") - 32	36	4.4	11/64	0.1740	0.1700	0.2001	0.1848	0.1820	0.1839	0.1820	0.1339
1/4 (.2500") - 28	32	5.1	13/64	0.2010	0.1970	0.2306	0.2133	0.2103	0.2123	0.2103	0.1562
5/16 (.3125") - 24	28	6.6	17/64	0.2640	0.2580	0.2964	0.2765	0.2732	0.2754	0.2732	0.2113
3/8 (.3750") - 24	24	8.2	21/64	0.3280	0.3220	0.3666	0.3433	0.3395	0.3421	0.3395	0.2674
7/16 (.4375") - 20	24	9.8	25/64	0.3900	0.3840	0.4291	0.4059	0.4020	0.4047	0.4020	0.3299
1/2 (.500") - 20	20	11.5	29/64	0.4560	0.4490	0.5025	0.4744	0.4700	0.4731	0.4700	0.3834
9/16 (.5625") - 18	20	13.0	33/64	0.5180	0.5110	0.5650	0.5371	0.5325	0.5357	0.5325	0.4459
5/8 (.6250") - 18	18	14.5	37/64	0.5820	0.5750	0.6347	0.6035	0.5986	0.6020	0.5986	0.5024
3/4 (.7500") - 16	18	16.25	41/64	0.6440	0.6370	0.6972	0.6661	0.6611	0.6646	0.6611	0.5649
7/8 (.8750") - 14	16	19.5	49/64	0.7710	0.7640	0.8312	0.7961	0.7906	0.7945	0.7906	0.6823
1 (1.0000") - 14	14	22.5	57/64	0.8990	0.8910	0.9678	0.9274	0.9214	0.9257	0.9214	0.7977
1 (1.0000") - 12	12	26.0	11/54	1.0280	1.0180	1.1083	1.0608	1.0542	1.0589	1.0542	0.9098
1 1/8 (1.1250") - 12	12	29.5	15/32	1.1530	1.1430	1.2333	1.1860	1.1792	1.1841	1.1792	1.0348
1 1/4 (1.2500") - 12	12	32.5	19/32	1.2780	1.2680	1.3583	1.3112	1.3042	1.3092	1.3042	1.1598
1 3/8 (1.3750") - 12	12	36.0	113/32	1.4030	1.3930	1.4833	1.4364	1.4292	1.4343	1.4292	1.2848
1 1/2 (1.5000") - 12	12	39.0	117/32	1.5280	1.5180	1.6083	1.5615	1.5542	1.5595	1.5542	1.4098

Standard size drills are suggested even though in these sizes they vary slightly from minor diameter limits. Drill sizes are recommended only and test should be carried out to select the one suitable for the material involved.

Countersinking: It is recommended that a 120° countersink is provided before tapping to prevent a feather edge at the start of the lead thread. When design prevents the use of a countersink, any feather edges or deformed material at the thread lead should be removed before tapping. This will facilitate insert installation and reduce the effects of removing the countersinking operation.

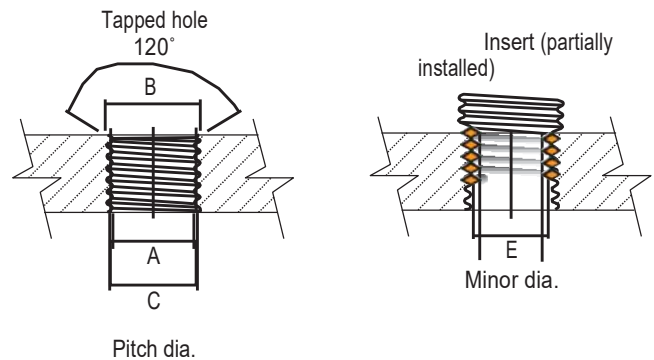

Recoil® Inserts Metric - Dimensions

Thread Size	1D		1.5D		2D		2.5D		3D		Free Coil Diameter		Number of Free Coils Nominal Length				
	Inch	mm	Inch	mm	Inch	mm	Inch	mm	Inch	mm	Min	Max	1D	1.5D	2D	2.5D	3D
Metric Coarse																	
M2 - 0.4	0.079	2.0	0.118	3.0	0.157	4.0	0.197	5.0	0.236	6.0	2.50	2.70	-	5.500	7.750	10.125	12.375
M2.2-0.45	0.087	2.2	0.130	3.3	0.173	4.4	0.217	5.5	0.260	6.6	2.80	3.00	3.125	5.375	7.625	9.875	12.125
M2.5-0.45	0.098	2.5	0.150	3.8	0.197	5.0	0.248	6.3	0.295	7.5	3.20	3.70	3.375	5.750	8.125	10.500	12.750
M3 - 0.5	0.118	3.0	0.177	4.5	0.236	6.0	0.295	7.5	0.354	9.0	3.80	4.35	3.750	6.375	8.875	11.375	13.875
M3.5 - 0.6	0.138	3.5	0.209	5.3	0.276	7.0	0.346	8.8	0.413	10.5	4.40	4.95	3.750	6.375	8.625	11.375	13.625
M4 - 0.7	0.157	4.0	0.236	6.0	0.315	8.0	0.394	10.0	0.472	12.0	5.05	5.60	3.625	6.125	8.625	11.125	13.625
M5 - 0.8	0.197	5.0	0.295	7.5	0.394	10.0	0.492	12.5	0.591	15.0	6.25	6.80	4.125	6.875	9.625	12.375	15.125
M6 - 1	0.236	6.0	0.354	9.0	0.472	12.0	0.591	15.0	0.709	18.0	7.40	7.95	4.000	6.750	9.500	12.125	14.875
M7 - 1	0.276	7.0	0.413	10.5	0.551	14.0	0.689	17.5	0.827	21.0	8.65	9.20	4.875	8.000	11.125	14.125	17.250
M8 - 0.75	0.315	8.0	0.472	12.0	0.630	16.0	0.787	20.0	0.945	24.0	9.00	9.51	8.600	13.750	18.750	-	-
M8 - 1.25	0.315	8.0	0.472	12.0	0.630	16.0	0.787	20.0	0.945	24.0	9.80	10.35	4.500	7.375	10.250	13.250	16.125
M9 - 1	0.354	9.0	0.531	13.5	0.709	18.0	0.886	22.5	1.063	27.0	10.40	10.65	7.050	11.350	15.650	19.850	24.150
M10 - 1.5	0.394	10.0	0.591	15.0	0.787	20.0	0.984	25.0	1.181	30.0	11.95	12.50	4.875	8.000	11.125	14.250	17.375
M12-1.75	0.472	12.0	0.709	18.0	0.945	24.0	1.181	30.0	1.417	36.0	14.30	15.00	5.000	8.250	11.500	14.625	17.875
M14 - 2	0.551	14.0	0.827	21.0	1.102	28.0	1.378	35.0	1.654	42.0	16.65	17.35	5.125	8.500	11.750	15.000	18.375
M16 - 2	0.630	16.0	0.945	24.0	1.260	32.0	1.575	40.0	1.890	48.0	18.90	19.60	6.125	9.750	13.500	17.250	21.000
M18 - 2.5	0.709	18.0	1.063	27.0	1.417	36.0	1.772	45.0	2.126	54.0	21.30	22.00	5.375	8.875	12.250	15.625	19.000
M20 - 2.5	0.787	20.0	1.181	30.0	1.575	40.0	1.969	50.0	2.362	60.0	23.55	24.40	6.125	9.875	13.625	17.375	21.125
M22 - 2.5	0.866	22.0	1.299	33.0	1.732	44.0	2.165	55.0	2.598	66.0	25.90	26.90	6.750	10.875	14.875	19.000	23.125
M24 - 3	0.945	24.0	1.417	36.0	1.890	48.0	2.362	60.0	2.835	72.0	28.00	29.00	6.125	10.000	13.750	17.500	21.375
M26 - 1.5	1.024	26.0	1.535	39.0	2.047	52.0	2.559	65.0	3.071	78.0	28.10	28.60	15.150	23.450	31.750	40.050	48.350
M27 - 3	1.063	27.0	1.594	40.5	2.126	54.0	2.657	67.5	3.189	81.0	31.40	32.40	7.000	11.250	15.500	19.750	24.000
M30 - 3	1.181	30.0	1.772	45.0	2.362	60.0	2.953	75.0	3.543	90.0	34.90	36.10	7.875	12.500	17.125	21.875	26.500
M33 - 3	1.299	33.0	1.949	49.5	2.598	66.0	3.248	82.5	3.898	99.0	38.10	39.50	8.750	13.875	19.000	24.125	29.250
M36 - 3	1.417	36.0	2.126	54.0	2.835	72.0	3.543	90.0	4.252	108.0	41.30	42.70	9.750	15.250	20.875	26.500	32.000
M39 - 3	1.535	39.0	2.303	58.5	3.071	78.0	3.839	97.5	4.606	117.0	44.40	45.80	10.750	16.750	22.750	28.875	34.875
M42 - 4.5	1.654	42.0	2.480	63.0	3.307	84.0	4.133	105.0	4.960	126.0	48.50	51.45	7.350	11.850	16.350	20.850	25.350
M48 - 5	1.889	48.0	2.835	72.0	3.779	96.0	4.724	120.0	5.669	144.0	55.45	57.10	-	12.150	17.100	-	-
M52 - 5	2.047	52.0	3.071	78.0	4.094	104.0	5.118	130.0	6.141	156.0	59.50	61.00	13.450	18.000	-	-	-



Recoil® Inserts Metric - Dimensions

Thread Size	1D		1.5D		2D		2.5D		3D		Free Coil Diameter		Number of Free Coils Nominal Length				
	Inch	mm	Inch	mm	Inch	mm	Inch	mm	Inch	mm	Min	Max	1D	1.5D	2D	2.5D	3D
Metric Fine																	
M8 - 1	0.315	8.0	0.472	12.0	0.630	16.0	0.787	20.0	0.945	24.0	9.70	10.25	5.875	9.375	13.000	16.500	20.125
M9 - 1.25	0.354	9.0	0.531	13.5	0.709	18.0	0.886	22.5	1.063	27.0	10.68	10.95	9.000	13.500	18.000	22.500	27.000
M10 - 1	0.394	10.0	0.591	15.0	0.787	20.0	0.984	25.0	1.181	30.0	11.95	12.50	7.625	12.000	16.500	21.000	25.500
M10-1.25	0.394	10.0	0.591	15.0	0.787	20.0	0.984	25.0	1.181	30.0	12.10	12.65	5.875	9.500	13.125	16.750	20.375
M11-1.25	0.433	11.0	0.650	16.5	0.866	22.0	1.083	27.5	1.299	33.0	12.83	13.10	6.900	11.000	15.150	19.350	23.450
M11 - 1	0.433	11.0	0.650	16.5	0.866	22.0	1.083	27.5	1.299	33.0	12.40	12.70	8.950	14.150	19.350	24.550	29.750
M12-1.25	0.472	12.0	0.709	18.0	0.945	24.0	1.181	30.0	1.417	36.0	14.30	15.00	7.250	11.625	15.875	20.250	24.500
M12 - 1.5	0.472	12.0	0.709	18.0	0.945	24.0	1.181	30.0	1.417	36.0	14.25	14.95	6.000	9.625	13.375	17.000	20.750
M12 - 1	0.472	12.0	0.709	18.0	0.945	24.0	1.181	30.0	1.417	36.0	13.55	13.90	10.250	15.350	21.300	-	-
M13 - 1.5	0.512	13.0	0.768	19.5	1.023	26.0	1.279	32.5	1.535	39.0	15.20	15.60	6.650	10.750	14.950	-	-
M13-1.25	0.512	13.0	0.768	19.5	1.023	26.0	1.279	32.5	1.535	39.0	14.70	15.05	8.350	13.250	18.250	23.150	28.150
M14 - 1.5	0.551	14.0	0.827	21.0	1.102	28.0	1.378	35.0	1.654	42.0	16.55	17.25	7.125	11.375	15.625	20.000	24.250
M15 - 1.5	0.591	15.0	0.886	22.5	1.181	30.0	1.476	37.5	1.772	45.0	17.25	17.65	7.950	12.750	17.450	22.250	26.950
M16-1.5	0.63	16.0	0.945	24.0	1.260	32.0	1.575	40.0	1.890	48.0	18.90	19.60	8.250	13.125	18.000	22.750	27.625
M18-1.5	0.709	18.0	1.063	27.0	1.417	36.0	1.772	45.0	2.126	54.0	21.05	21.75	9.500	15.000	20.375	25.875	31.375
M18 - 2	0.709	18.0	1.063	27.0	1.417	36.0	1.772	45.0	2.126	54.0	21.15	21.85	7.000	11.125	15.375	19.500	23.625
M20 - 1.5	0.787	20.0	1.181	30.0	1.575	40.0	1.969	50.0	2.362	60.0	23.15	24.00	10.750	16.875	22.875	28.875	35.000
M20 - 2	0.787	20.0	1.181	30.0	1.575	40.0	1.969	50.0	2.362	60.0	23.20	24.05	7.875	12.500	17.250	21.875	26.500
M22 - 1.5	0.866	22.0	1.299	33.0	1.732	44.0	2.165	55.0	2.598	66.0	25.55	26.45	11.875	18.500	25.125	31.625	38.250
M22 - 2	0.787	20.0	1.181	30.0	1.575	40.0	1.969	50.0	2.362	60.0	25.60	26.50	8.750	13.750	18.875	23.875	29.000
M24 - 2	0.945	24.0	1.417	36.0	1.890	48.0	2.362	60.0	2.835	72.0	28.10	29.10	9.500	15.000	20.375	25.875	31.250
M24 - 1.5	0.945	24.0	1.417	36.0	1.890	48.0	2.362	60.0	2.835	72.0	26.10	26.60	13.850	21.550	29.150	36.850	44.450
M27 - 1.5	1.063	27.0	1.594	40.5	2.126	54.0	2.657	67.5	3.189	81.0	29.10	30.00	15.850	24.450	33.150	41.800	50.450
M27 - 2	1.063	27.0	1.594	40.5	2.126	54.0	2.657	67.5	3.189	81.0	31.30	32.30	10.875	17.000	23.250	29.375	35.500
M30 - 1.5	1.181	30.0	1.772	45.0	2.362	60.0	2.953	75.0	3.543	90.0	32.50	32.80	17.450	26.950	36.550	46.050	55.550
M30 - 2	1.181	30.0	1.772	45.0	2.362	60.0	2.953	75.0	3.543	90.0	34.50	35.70	12.250	19.125	25.875	32.750	39.500
M30 - 3.5	1.181	30.0	1.772	45.0	2.362	60.0	2.953	75.0	3.543	90.0	34.85	35.75	6.650	10.750	14.900	18.950	23.150
M33 - 2	1.299	33.0	1.949	49.5	2.598	66.0	3.248	82.5	3.898	99.0	37.80	39.20	13.625	21.125	28.625	36.000	43.500
M33 - 3.5	1.299	33.0	1.949	49.5	2.598	66.0	3.248	82.5	3.898	99.0	38.20	38.74	7.550	11.950	16.400	21.150	25.300
M36 - 1.5	1.417	36.0	2.126	54.0	2.835	72.0	3.543	90.0	4.252	108.0	38.45	38.95	22.150	33.950	45.750	57.650	69.450
M36 - 2	1.417	36.0	2.126	54.0	2.835	72.0	3.543	90.0	4.252	108.0	41.00	42.40	15.000	23.250	31.375	39.500	47.750
M36 - 4	1.417	36.0	2.126	54.0	2.835	72.0	3.543	90.0	4.252	108.0	41.90	42.90	7.000	11.350	15.750	20.050	24.350
M39 - 2	1.535	39.0	2.303	58.5	3.071	78.0	3.839	97.5	4.606	117.0	44.30	45.70	16.375	25.250	34.125	43.000	51.870
M39 - 4	1.535	39.0	2.303	58.5	3.071	78.0	3.839	97.5	4.606	117.0	45.05	46.05	7.800	12.500	17.150	21.850	23.550
M42 - 2	1.654	42.0	2.480	63.0	3.307	84.0	4.133	105.0	4.960	126.0	44.70	46.10	19.150	29.450	39.850	50.150	60.450
M42 - 3	1.654	42.0	2.480	63.0	3.307	84.0	4.133	105.0	4.960	126.0	47.20	50.35	11.750	18.450	26.050	31.750	38.450
M42 - 4	1.654	42.0	2.480	63.0	3.307	84.0	4.133	105.0	4.960	126.0	48.50	51.45	8.5000	13.450	18.650	23.650	28.650
M45 - 3	1.771	45.0	2.657	67.5	3.543	90.0	4.429	112.5	5.314	135.0	50.30	52.00	12.700	19.850	26.950	34.150	41.250
M48 - 3	1.889	48.0	2.835	72.0	3.779	96.0	4.724	120.0	5.669	144.0	52.50	54.50	13.650	21.250	28.850	36.450	44.150
M48 - 4	1.889	48.0	2.835	72.0	3.779	96.0	4.724	120.0	5.669	144.0	53.80	55.00	-	15.550	-	-	-
M52 - 3	2.047	52.0	3.071	78.0	4.094	104.0	5.118	130.0	6.141	156.0	57.30	58.50	15.000	23.200	-	-	-

MS Insert Dimensional Data

Drawing Call-Out

An example of a typical drawing specification for a Recoil® insert is shown below:

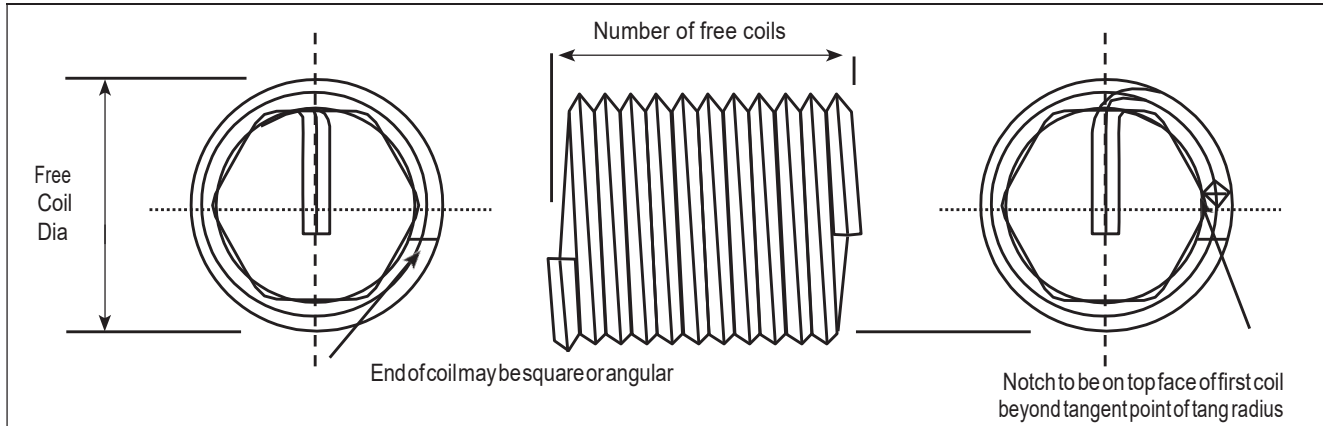

1. Recoil insert part number 14063
 2. Size and location of notch, shape of tang, reduced first coil & all dimensions not shown will be produced to Recoil standards
 3. Number of free coils to be counted from the notch

Name	Material Stainless Steel AS 7245	Description Insert 3/8" - 24 x 1 1/2 D .562" Long St. STL
Name	Part No.	Manufacturer AFS

A typical drawing call-out for a Recoil screw-locking insert 3/8 - 24 x 1 1/2 dia. long Class 3B Unified Fine Thread (UNF) is shown. Drawing call-outs can be simply defined by using a production sequence process sheet to provide the operational steps with the drawing showing dimensional limits and data. (Example shown below)

- 1) Drill hole 25/64" (.3906") diameter, depth .812" plus your normal standard for drilling depth.
- 2) Countersink 120° +/-5° .42"/.45" diameter.
- 3) Tap with Recoil STI Tap No. 44065 (class 3B) full thread depth .600".
- 4) Gauge with Recoil Gauge No. 64063 or according to your inspection requirements.
- 5) Install Recoil screw-lock insert 14063 with Recoil Inserting Tool No. 54061.
- 6) Break off driving tang with Recoil Tang Break-off Tool No. 59280M.

Recoil® Thread Insert Part Numbering System

Recoil insert product part numbering system uses a logically structured 5 digit basic part number. Suffixes are typically added to differentiate between special or non-standard features. This guide

defines the structure of Recoil part numbers and may be used for reference to identify a Recoil insert from its part number.

Diagram of Recoil Insert Part Number Example

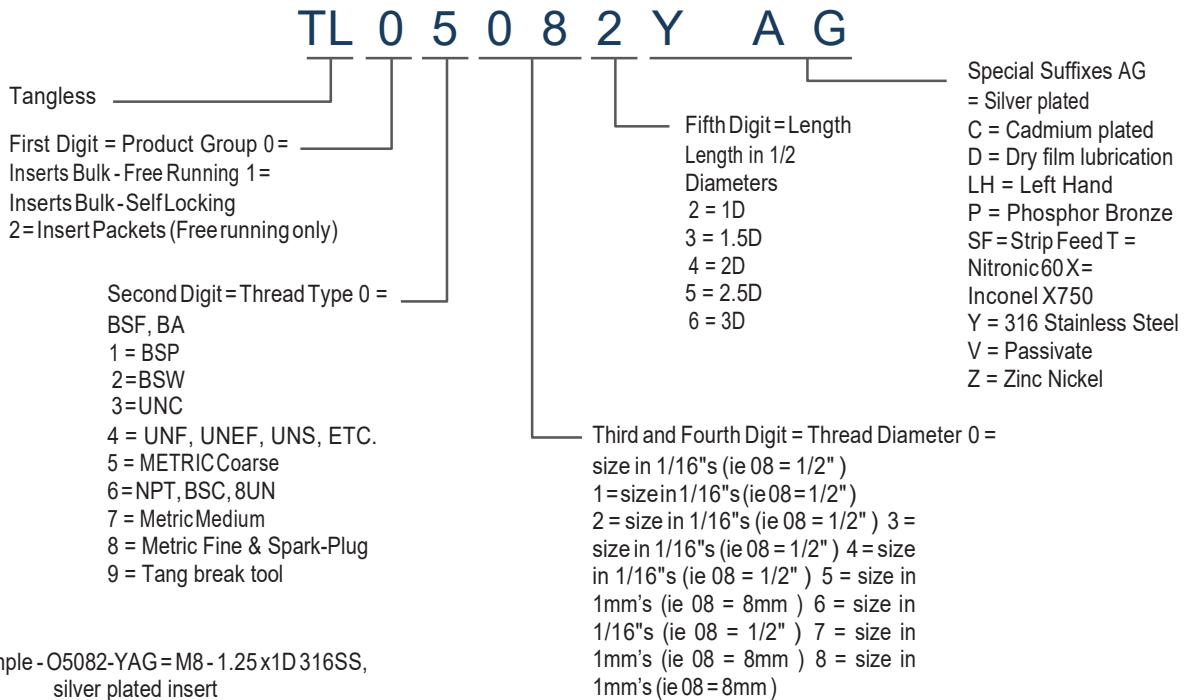

Tanged Free Running Insert

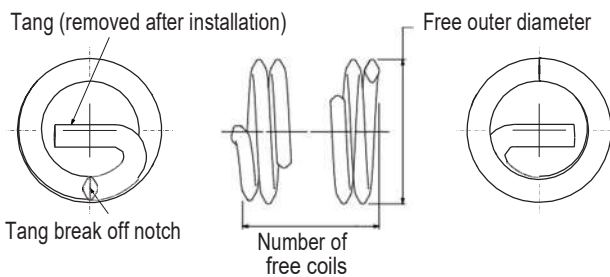

Tanged Locking Insert

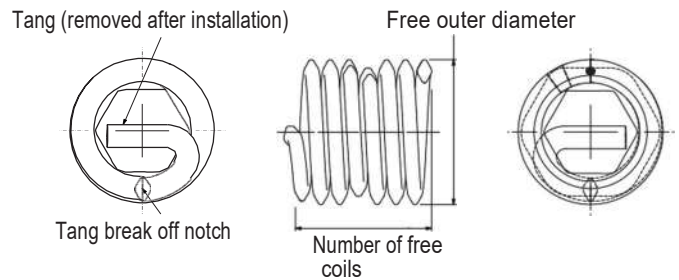

Tangless® Free Running Insert

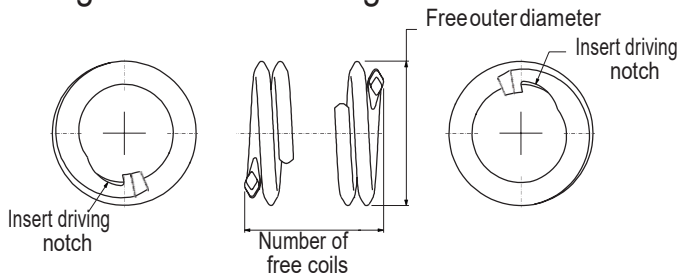

Tangless® Locking Insert

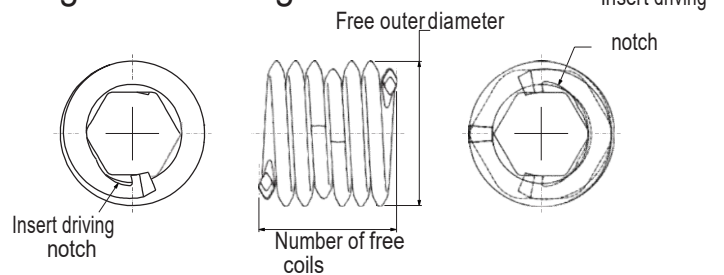



Recoil® Part Numbers Cross Reference - Tanged and Tangless®

Metric - Free Running Series

Thread Size	Nominal Length (in Dia.)	Tangless		Tanged		
		Recoil Part Number	NA Tangless Part Number	Recoil Part Number	Recoil MA Part Number	SAE MA Part Number
M2 - 0.4	1	TL05022	-	05022	-	MA3279-140
	1.5	TL05023	-	05023	-	MA3279-190
	2	TL05024	-	05024	-	MA3279-240
	2.5	-	-	05025	-	MA3279-290
	3	-	-	05026	-	MA3279-340
M2.2 - 0.45	1	-	-	05012	05012MA	MA3279-100
	1.5	-	-	05013	05013MA	MA3279-150
	2	-	-	05014	05014MA	MA3279-200
	2.5	-	-	05015	05015MA	MA3279-250
	3	-	-	05016	05016MA	MA3279-300
M2.5 - 0.45	1	TL05252	NA0276M2-10	05252	05252MA	MA3279-101
	1.5	TL05253	NA0276M2-15	05253	05253MA	MA3279-151
	2	TL05254	NA0276M2-20	05254	05254MA	MA3279-201
	2.5	TL05255	NA0276M2-25	05255	05255MA	MA3279-251
	3	TL05256	NA0276M2-30	05256	05256MA	MA3279-301
M3 - 0.5	1	TL05032	NA0276M3-10	05032	05032MA	MA3279-102
	1.5	TL05033	NA0276M3-15	05033	05033MA	MA3279-152
	2	TL05034	NA0276M3-20	05034	05034MA	MA3279-202
	2.5	TL05035	NA0276M3-25	05035	05035MA	MA3279-252
	3	TL05036	NA0276M3-30	05036	05036MA	MA3279-302
M3.5 - 0.6	1	-	-	05352	05352MA	MA3279-103
	1.5	-	-	05353	05353MA	MA3279-153
	2	-	-	05354	05354MA	MA3279-203
	2.5	-	-	05355	05355MA	MA3279-253
	3	-	-	05356	05356MA	MA3279-303
M4 - 0.7	1	TL05042	NA0276M4-10	05042	05042MA	MA3279-104
	1.5	TL05043	NA0276M4-15	05043	05043MA	MA3279-154
	2	TL05044	NA0276M4-20	05044	05044MA	MA3279-204
	2.5	TL05045	NA0276M4-25	05045	05045MA	MA3279-254
	3	TL05046	NA0276M4-30	05046	05046MA	MA3279-304
M5 - 0.8	1	TL05052	NA0276M5-10	05052	05052MA	MA3279-105
	1.5	TL05053	NA0276M5-15	05053	05053MA	MA3279-155
	2	TL05054	NA0276M5-20	05054	05054MA	MA3279-205
	2.5	TL05055	NA0276M5-25	05055	05055MA	MA3279-255
	3	TL05056	NA0276M5-30	05056	05056MA	MA3279-305
M6 - 1	1	TL05062	NA0276M6-10	05062	05062MA	MA3279-106
	1.5	TL05063	NA0276M6-15	05063	05063MA	MA3279-156
	2	TL05064	NA0276M6-20	05064	05064MA	MA3279-206
	2.5	TL05065	NA0276M6-25	05065	05065MA	MA3279-256
	3	TL05066	NA0276M6-30	05066	05066MA	MA3279-306
M7 - 1	1	-	-	05072	05072MA	MA3279-107
	1.5	-	-	05073	05073MA	MA3279-157
	2	-	-	05074	05074MA	MA3279-207
	2.5	-	-	05075	05075MA	MA3279-257
	3	-	-	05076	05076MA	MA3279-307

Recoil® Part Numbers Cross Reference - Tanged and Tangless®

Metric - Free Running Series

Thread Size	Nominal Length (in Dia.)	Tangless		Tanged		
		Recoil Part Number	NA Tangless Part Number	Recoil Part Number	Recoil MA Part Number	SAE MA Part Number
M8 - 1	1	-	-	07082	07082MA	MA3279-108
	1.5	-	-	07083	07083MA	MA3279-158
	2	-	-	07084	07084MA	MA3279-208
	2.5	-	-	07085	07085MA	MA3279-258
	3	-	-	07086	07086MA	MA3279-308
M8 - 1.25	1	TL05082	NA0276M8-10	05082	-	MA3279-109
	1.5	TL05083	NA0276M8-15	05083	-	MA3279-159
	2	TL05084	NA0276M8-20	05084	-	MA3279-208
	2.5	TL05085	NA0276M8-25	05085	-	MA3279-258
	3	TL05086	NA0276M8-30	05086	-	MA3279-308
M9 - 1.25	1	-	-	05092	-	-
	1.5	-	-	05093	-	-
	2	-	-	05094	-	-
	2.5	-	-	05095	-	-
	3	-	-	05096	-	-
M10 - 1	1	-	-	08102	08102MA	MA3279-141
	1.5	-	-	08103	08103MA	MA3279-191
	2	-	-	08104	08104MA	MA3279-241
	2.5	-	-	08105	08105MA	MA3279-291
	3	-	-	08106	08106MA	MA3279-341
M10 - 1.25	1	-	-	07102	07102MA	MA3279-110
	1.5	-	-	07103	07103MA	MA3279-160
	2	-	-	07104	07104MA	MA3279-210
	2.5	-	-	07105	07105MA	MA3279-260
	3	-	-	07106	07106MA	MA3279-310
M10 - 1.5	1	TL05102	NA0276M10-10	05102	-	MA3279-111
	1.5	TL05103	NA0276M10-15	05103	-	MA3279-161
	2	TL05104	NA0276M10-20	05104	-	MA3279-211
	2.5	TL05105	NA0276M10-25	05105	-	MA3279-261
	3	TL05106	NA0276M10-30	05106	-	MA3279-311
M11 - 1.5	1	-	-	05112	-	-
	1.5	-	-	05113	-	-
	2	-	-	05114	-	-
	2.5	-	-	05115	-	-
	3	-	-	05116	-	-
M12 - 1	1	-	-	08122-1	-	-
	1.5	-	-	08123-1	-	-
	2	-	-	08124-1	-	-
	2.5	-	-	08125-1	-	-
	3	-	-	08126-1	-	-
M12 - 1.25	1	-	-	08122	08122MA	MA3279-112
	1.5	-	-	08123	08123MA	MA3279-162
	2	-	-	08124	08124MA	MA3279-212
	2.5	-	-	08125	08125MA	MA3279-262
	3	-	-	08126	08126MA	MA3279-312



Recoil® Part Numbers Cross Reference - Tanged and Tangless®

Metric - Free Running Series

Thread Size	Nominal Length (in Dia.)	Tangless		Tanged		
		Recoil Part Number	NA Tangless Part Number	Recoil Part Number	Recoil MA Part Number	SAE MA Part Number
M12 - 1.5	1	TL05122	NA0276M12-10	07122	07122MA	MA3279-113
	1.5	TL05123	NA0276M12-15	07123	07123MA	MA3279-163
	2	TL05124	NA0276M12-20	07124	07124MA	MA3279-213
	2.5	TL05125	NA0276M12-25	07125	07125MA	MA3279-263
	3	TL05126	NA0276M12-30	07126	07126MA	MA3279-313
M12 - 1.75	1	TL05122	NA0276M12-10	05122	-	MA3279-114
	1.5	TL05123	NA0276M12-15	05123	-	MA3279-164
	2	TL05124	NA0276M12-20	05124	-	MA3279-214
	2.5	TL05125	NA0276M12-25	05125	-	MA3279-264
	3	TL05126	NA0276M12-30	05126	-	MA3279-314
M14 - 1.5	1	-	-	07142	07142MA	MA3279-115
	1.5	-	-	07143	07143MA	MA3279-165
	2	-	-	07144	07144MA	MA3279-215
	2.5	-	-	07145	07145MA	MA3279-265
	3	-	-	07146	07146MA	MA3279-315
M14 - 2	1	TL05142	-	05142	-	MA3279-116
	1.5	TL05143	-	05143	-	MA3279-166
	2	TL05144	-	05144	-	MA3279-216
	2.5	-	-	05145	-	MA3279-266
	3	-	-	05146	-	MA3279-316
M16 - 1.5	1	-	-	07162	07162MA	MA3279-117
	1.5	-	-	07163	07163MA	MA3279-167
	2	-	-	07164	07164MA	MA3279-217
	2.5	-	-	07165	07165MA	MA3279-267
	3	-	-	07166	07166MA	MA3279-317
M16 - 2	1	TL05162	-	05162	-	MA3279-118
	1.5	TL05163	-	05163	-	MA3279-168
	2	TL05164	-	05164	-	MA3279-218
	2.5	-	-	05165	-	MA3279-268
	3	-	-	05166	-	MA3279-318
M18 - 1.5	1	-	-	08182	08182MA	MA3279-119
	1.5	-	-	08183	08183MA	MA3279-169
	2	-	-	08184	08184MA	MA3279-219
	2.5	-	-	08185	08185MA	MA3279-269
	3	-	-	08186	08186MA	MA3279-319
M18 - 2	1	-	-	07182	07182MA	MA3279-120
	1.5	-	-	07183	07183MA	MA3279-170
	2	-	-	07184	07184MA	MA3279-220
	2.5	-	-	07185	07185MA	MA3279-270
	3	-	-	07186	07186MA	MA3279-320
M18 - 2.5	1	-	-	05182	-	MA3279-121
	1.5	-	-	05183	-	MA3279-171
	2	-	-	05184	-	MA3279-221
	2.5	-	-	05185	-	MA3279-271
	3	-	-	05186	-	MA3279-321

Recoil® Part Numbers Cross Reference - Tanged and Tangless®

Metric - Free Running Series

Thread Size	Nominal Length (in Dia.)	Tangless		Tanged		
		Recoil Part Number	NA Tangless Part Number	Recoil Part Number	Recoil MA Part Number	SAE MA Part Number
M20 - 1.5	1	-	-	08202	08202MA	MA3279-122
	1.5	-	-	08203	08203MA	MA3279-172
	2	-	-	08204	08204MA	MA3279-222
	2.5	-	-	08205	08205MA	MA3279-272
	3	-	-	08206	08206MA	MA3279-322
M20 - 2	1	-	-	07202	07202MA	MA3279-123
	1.5	-	-	07203	07203MA	MA3279-173
	2	-	-	07204	07204MA	MA3279-223
	2.5	-	-	07205	07205MA	MA3279-273
	3	-	-	07206	07206MA	MA3279-323
M20 - 2.5	1	-	-	05202	-	MA3279-124
	1.5	-	-	05203	-	MA3279-174
	2	-	-	05204	-	MA3279-224
	2.5	-	-	05205	-	MA3279-274
	3	-	-	05206	-	MA3279-324
M22 - 1.5	1	-	-	08222	08222MA	MA3279-125
	1.5	-	-	08223	08223MA	MA3279-175
	2	-	-	08224	08224MA	MA3279-225
	2.5	-	-	08225	08225MA	MA3279-275
	3	-	-	08226	08226MA	MA3279-325
M22 - 2	1	-	-	07222	07222MA	MA3279-126
	1.5	-	-	07223	07223MA	MA3279-176
	2	-	-	07224	07224MA	MA3279-226
	2.5	-	-	07225	07225MA	MA3279-276
	3	-	-	07226	07226MA	MA3279-326
M22 - 2.5	1	-	-	05222	-	MA3279-127
	1.5	-	-	05223	-	MA3279-177
	2	-	-	05224	-	MA3279-227
	2.5	-	-	05225	-	MA3279-277
	3	-	-	05226	-	MA3279-327
M24 - 1.5	1	-	-	08242	-	-
	1.5	-	-	08243	-	-
	2	-	-	08244	-	-
	2.5	-	-	08245	-	-
	3	-	-	08246	-	-
M24 - 2	1	-	-	07242	07242MA	MA3279-128
	1.5	-	-	07243	07243MA	MA3279-178
	2	-	-	07244	07244MA	MA3279-228
	2.5	-	-	07245	07245MA	MA3279-278
	3	-	-	07246	07246MA	MA3279-328
M24 - 3	1	-	-	05242	-	MA3279-129
	1.5	-	-	05243	-	MA3279-179
	2	-	-	05244	-	MA3279-229
	2.5	-	-	05245	-	MA3279-279
	3	-	-	05246	-	MA3279-329



Recoil® Part Numbers Cross Reference - Tanged and Tangless®

Metric - Free Running Series

Thread Size	Nominal Length (in Dia.)	Tangless		Tanged		
		Recoil Part Number	NA Tangless Part Number	Recoil Part Number	Recoil MA Part Number	SAE MA Part Number
M26 - 1.5	1	-	-	08262	-	-
	1.5	-	-	08263	-	-
	2	-	-	-	-	-
	2.5	-	-	-	-	-
	3	-	-	-	-	-
M27 - 1.5	1	-	-	08272	-	-
	1.5	-	-	08273	-	-
	2	-	-	-	-	-
	2.5	-	-	-	-	-
	3	-	-	-	-	-
M27 - 2	1	-	-	07272	07272MA	MA3279-130
	1.5	-	-	07273	07273MA	MA3279-180
	2	-	-	07274	07274MA	MA3279-230
	2.5	-	-	07275	07275MA	MA2379-280
	3	-	-	07276	07276MA	MA3279-330
M27 - 3	1	-	-	05272	-	MA3279-131
	1.5	-	-	05273	-	MA3279-161
	2	-	-	05274	-	MA3279-231
	2.5	-	-	05275	-	MA3279-281
	3	-	-	05276	-	MA3279-331
M30 - 1.5	1	-	-	08302	-	-
	1.5	-	-	08303	-	-
	2	-	-	08304	-	-
	2.5	-	-	08305	-	-
	3	-	-	08306	-	-
M30 - 2	1	-	-	07302	07302MA	MA3279-132
	1.5	-	-	07303	07303MA	MA3279-182
	2	-	-	07304	07304MA	MA3279-232
	2.5	-	-	07305	07305MA	MA3279-282
	3	-	-	07306	07306MA	MA2379-332
M30 - 3	1	-	-	05302-3	05302-3MA	MA3279-133
	1.5	-	-	05303-3	05303-3MA	MA3279-183
	2	-	-	05304-3	05304-3MA	MA3279-233
	2.5	-	-	05305-3	05305-3MA	MA3279-283
	3	-	-	05360-3	05360-3MA	MA3279-333
M30 - 3.5	1	-	-	05302	-	-
	1.5	-	-	05303	-	-
	2	-	-	05304	-	-
	2.5	-	-	05305	-	-
	3	-	-	05306	-	-
M33 - 2	1	-	-	07332	07332MA	MA3279-134
	1.5	-	-	07333	07333MA	MA3279-184
	2	-	-	07334	07334MA	MA3279-234
	2.5	-	-	07335	07335MA	MA3279-284
	3	-	-	07336	07336MA	MA3279-334

Recoil® Part Numbers Cross Reference - Tanged and Tangless®

Metric - Free Running Series

Thread Size	Nominal Length (in Dia.)	Tangless		Tanged		
		Recoil Part Number	NA Tangless Part Number	Recoil Part Number	Recoil MA Part Number	SAE MA Part Number
M33 - 3	1	-	-	07332-3	07332-3MA	MA3279-135
	1.5	-	-	07333-3	07333-3MA	MA3279-185
	2	-	-	07334-3	07334-3MA	MA3279-235
	2.5	-	-	07335-3	07335-3MA	MA3279-285
	3	-	-	07336-3	07336-3MA	MA3279-335
M33 - 3.5	1	-	-	05332	-	-
	1.5	-	-	05333	-	-
	2	-	-	05334	-	-
	2.5	-	-	-	-	-
	3	-	-	-	-	-
M36 - 1.5	1	-	-	08362	-	-
	1.5	-	-	08363	-	-
	2	-	-	08364	-	-
	2.5	-	-	-	-	-
	3	-	-	-	-	-
M36 - 2	1	-	-	07362-2	07362-2MA	MA3279-136
	1.5	-	-	07363-2	07363-2MA	MA3279-186
	2	-	-	07364-2	07364-2MA	MA3279-236
	2.5	-	-	07365-2	07365-2MA	MA3279-286
	3	-	-	07366-2	07366-2MA	MA3279-336
M36 - 3	1	-	-	07362	07362MA	MA3279-137
	1.5	-	-	07363	07363MA	MA3279-187
	2	-	-	07364	07364MA	MA3279-237
	2.5	-	-	07365	07365MA	MA3279-287
	3	-	-	07366	07366MA	MA3279-337
M36 - 4	1	-	-	05362	-	-
	1.5	-	-	05363	-	-
	2	-	-	05364	-	-
	2.5	-	-	-	-	-
	3	-	-	-	-	-
M39 - 2	1	-	-	08392	08392MA	MA3279-138
	1.5	-	-	08393	08393MA	MA3279-188
	2	-	-	08394	08394MA	MA3279-238
	2.5	-	-	08395	08395MA	MA3279-288
	3	-	-	08396	08396MA	MA3279-338
M39 - 3	1	-	-	07392	07392MA	MA3279-139
	1.5	-	-	07393	07393MA	MA3279-189
	2	-	-	07394	07394MA	MA3279-239
	2.5	-	-	07394	07394MA	MA3279-289
	3	-	-	07396	07396MA	MA3279-339
M39 - 4	1	-	-	05392	-	-
	1.5	-	-	05393	-	-
	2	-	-	05394	-	-
	2.5	-	-	-	-	-
	3	-	-	-	-	-



Recoil® Part Numbers Cross Reference - Tanged and Tangless®

Unified Coarse - Free Running Series

Thread Size	Nominal Length (in Dia.)	Tangless		Tanged	
		Recoil Part Number	NA/NAS Tangless Part Number	Recoil Part Number	SAE MS Part Number
#2 - 56	1	TL03522	NAS1130-02-10	03522	MS122095
	1.5	TL03523	NAS1130-02-15	03523	MS122135
	2	TL03524	NAS1130-02-20	03524	MS122175
	2.5	TL03525	NAS1130-02-25	03525	MS122215
	3	TL03526	NAS1130-02-30	03526	MS122255
#3 - 48	1	-	-	03532	MS122115
	1.5	-	-	03533	MS122155
	2	-	-	03534	MS122195
	2.5	-	-	03535	MS122235
	3	-	-	03536	MS122275
#4 - 40	1	TL03542	NAS1130-04-10	03542	MS122076
	1.5	TL03543	NAS1130-04-15	03543	MS122116
	2	TL03544	NAS1130-04-20	03544	MS122156
	2.5	TL03545	NAS1130-04-25	03545	MS122196
	3	TL03546	NAS1130-04-30	03546	MS122236
#5 - 40	1	-	-	03552	MS122077
	1.5	-	-	03553	MS122117
	2	-	-	03554	MS122157
	2.5	-	-	03555	MS122197
	3	-	-	03556	MS122237
#6 - 32	1	TL03562	NAS1130-06-10	03562	MS122078
	1.5	TL03563	NAS1130-06-15	03563	MS122118
	2	TL03564	NAS1130-06-20	03564	MS122158
	2.5	TL03565	NAS1130-06-25	03565	MS122198
	3	TL03566	NAS1130-06-30	03566	MS122238
#8 - 32	1	TL03582	NAS1130-08-10	03582	MS122079
	1.5	TL03583	NAS1130-08-15	03583	MS122119
	2	TL03584	NAS1130-08-20	03584	MS122159
	2.5	TL03585	NAS1130-08-25	03585	MS122199
	3	TL03586	NAS1130-08-30	03586	MS122239
#10 - 24	1	TL03602	NAS1130-3C-10	03602	MS122080
	1.5	TL03603	NAS1130-3C-15	03603	MS122120
	2	TL03604	NAS1130-3C-20	03604	MS122160
	2.5	TL03605	NAS1130-3C-25	03605	MS122200
	3	TL03606	NAS1130-3C-30	03606	MS122240
#12 - 24	1	-	-	03622	-
	1.5	-	-	03623	-
	2	-	-	03624	-
	2.5	-	-	03625	-
	3	-	-	03626	-
1/4 - 20	1	TL03042	NAS1130-4-10	03042	MS122081
	1.5	TL03043	NAS1130-4-15	03043	MS122121
	2	TL03044	NAS1130-4-20	03044	MS122161
	2.5	TL03045	NAS1130-4-25	03045	MS122201
	3	TL03046	NAS1130-4-30	03046	MS122241

Recoil® Part Numbers Cross Reference - Tanged and Tangless®

Unified Coarse - Free Running Series

Thread Size	Nominal Length (in Dia.)	Tangless		Tanged	
		Recoil Part Number	NA/NAS Tangless Part Number	Recoil Part Number	SAE MS Part Number
5/16 - 18	1	TL03052	NAS1130-5C-10	03052	MS122082
	1.5	TL03053	NAS1130-5C-15	03053	MS122122
	2	TL03054	NAS1130-5C-20	03054	MS122162
	2.5	TL03055	NAS1130-5C-25	03055	MS122202
	3	TL03056	NAS1130-5C-30	03056	MS122242
3/8 - 16	1	TL03062	NAS1130-6C-10	03062	MS122083
	1.5	TL03063	NAS1130-6C-15	03063	MS122123
	2	TL03064	NAS113-06C-20	03064	MS122163
	2.5	TL03065	NAS113-06C-25	03065	MS122203
	3	TL03066	NAS113-06C-30	03066	MS122243
7/16 - 14	1	-	-	03072	MS122084
	1.5	-	-	03073	MS122124
	2	-	-	03074	MS122164
	2.5	-	-	03075	MS122204
	3	-	-	03076	MS122244
1/2 - 13	1	TL03082	-	03082	MS122085
	1.5	TL03083	-	03083	MS122125
	2	TL03084	-	03084	MS122165
	2.5	-	-	03085	MS122205
	3	-	-	03086	MS122245
9/16 - 12	1	-	-	03092	MS122086
	1.5	-	-	03093	MS122126
	2	-	-	03094	MS122166
	2.5	-	-	03095	MS122206
	3	-	-	03096	MS122246
5/8 - 11	1	-	-	03102	MS122087
	1.5	-	-	03103	MS122127
	2	-	-	03104	MS122167
	2.5	-	-	03105	MS122207
	3	-	-	03106	MS122247
3/4 - 10	1	-	-	03122	MS122088
	1.5	-	-	03123	MS122128
	2	-	-	03124	MS122168
	2.5	-	-	03125	MS122208
	3	-	-	03126	MS122248
7/8 - 9	1	-	-	03142	MS122089
	1.5	-	-	03143	MS122129
	2	-	-	03144	MS122169
	2.5	-	-	03145	MS122209
	3	-	-	03146	MS122249
1 - 8	1	-	-	03162	MS122090
	1.5	-	-	03163	MS122130
	2	-	-	03164	MS122170
	2.5	-	-	03165	MS122210
	3	-	-	03166	MS122250

Recoil® Part Numbers Cross Reference - Tanged and Tangless®

Unified Coarse - Free Running Series

Thread Size	Nominal Length (in Dia.)	Tangless		Tanged	
		Recoil Part Number	NA/NAS Tangless Part Number	Recoil Part Number	SAE MS Part Number
1 1/8 - 7	1	-	-	03182	MS122091
	1.5	-	-	03183	MS122131
	2	-	-	03184	MS122171
	2.5	-	-	03185	MS122211
	3	-	-	03186	MS122251
1 1/4 - 7	1	-	-	03202	MS122092
	1.5	-	-	03203	MS122132
	2	-	-	03204	MS122172
	2.5	-	-	03205	MS122212
	3	-	-	03206	MS122252
1 3/8 - 6	1	-	-	03222	MS122093
	1.5	-	-	03223	MS122133
	2	-	-	03224	MS122173
	2.5	-	-	03225	MS122213
	3	-	-	03226	MS122253
1 1/2 - 6	1	-	-	03242	MS122094
	1.5	-	-	03243	MS122134
	2	-	-	03244	MS122174
	2.5	-	-	03245	MS122214
	3	-	-	03246	MS122254



Recoil® Part Numbers Cross Reference - Tanged and Tangless®

Unified Fine - Free Running Series

Thread Size	Nominal Length (in Dia.)	Tangless		Tanged		
		Recoil Part Number	NA/NAS Tangless Part Number	Recoil Part Number	Recoil MA Part Number	SAE MA Part Number
#3 - 56	1	-	-	04532	04532MS124670	MS21209-F0310
	1.5	-	-	04533	04533MS124710	MS21209-F0315
	2	-	-	04534	04534MS124750	MS21209-F0320
	2.5	-	-	04535	04535MS124790	MS21209-F0325
	3	-	-	04536	04536MS124830	MS21209-F0330
#4 - 48	1	-	-	04542	04542MS124671	MS21209-F0410
	1.5	-	-	04543	04543MS124711	MS21209-F0415
	2	-	-	04544	04544MS124751	MS21209-F0420
	2.5	-	-	04545	04545MS124791	MS21209-F0425
	3	-	-	04546	04546MS124831	MS21209-F0430
#6 - 40	1	-	-	04562	04562MS124653	MS21209-F0610
	1.5	-	-	04563	04563MS124693	MS21209-F0615
	2	-	-	04564	04564MS124733	MS21209-F0620
	2.5	-	-	04565	04565MS124773	MS21209-F0625
	3	-	-	04566	04566MS124813	MS21209-F0630
#8 - 36	1	-	-	04582	04581MS124654	MS21209-F0810
	1.5	-	-	04583	04583MS124694	MS21209-F0815
	2	-	-	04584	04584MS124734	MS21209-F0820
	2.5	-	-	04585	04585MS124774	MS21209-F0825
	3	-	-	04586	04586MS124814	MS21209-F0830
#10 - 32	1	TL04602	NAS1130-3-10	04602	04602MS124655	MS21209-F1-10
	1.5	TL04603	NAS1130-3-15	04603	04603MS124695	MS21209-F1-15
	2	TL04604	NAS1130-3-20	04604	04604MS124735	MS21209-F1-20
	2.5	TL04605	NAS1130-3-25	04605	04605MS124775	MS21209-F1-25
	3	TL04606	NAS1130-3-30	04606	04606MS124815	MS21209-F1-30
1/4 - 28	1	TL04042	NAS1130-4F-10	04042	04042MS124656	MS21209-F4-10
	1.5	TL04043	NAS1130-4F-15	04043	04043MS124696	MS21209-F4-15
	2	TL04044	NAS1130-4F-20	04044	04044MS124736	MS21209-F4-20
	2.5	TL04045	NAS1130-4F-25	04045	04045MS124776	MS21209-F4-25
	3	TL04046	NAS1130-4F-30	04046	04046MS124816	MS21209-F4-30
5/16 - 24	1	TL04052	NAS1130-5F-10	04052	04052MS124657	MS21209-F5-10
	1.5	TL04053	NAS1130-5F-15	04053	04053MS124697	MS21209-F5-15
	2	TL04054	NAS1130-5F-20	04054	04054MS124737	MS21209-F5-20
	2.5	TL04055	NAS1130-5F-25	04055	04055MS124777	MS21209-F5-25
	3	-	-	04056	04056MS124817	MS21209-F5-30
3/8 - 24	1	TL04062	NAS1130-6F-10	04062	04062MS124658	MS21209-F6-10
	1.5	TL04063	NAS1130-6F-15	04063	04063MS124698	MS21209-F6-15
	2	TL04064	NAS1130-6F-20	04064	04064MS124738	MS21209-F6-20
	2.5	-	-	04065	04065MS124778	MS21209-F6-25
	3	-	-	04066	04066MS124818	MS21209-F6-30
7/16 - 20	1	-	-	04072	04072MS124659	MS21209-F7-10
	1.5	-	-	04073	04073MS124699	MS21209-F7-15
	2	-	-	04074	04074MS124739	MS21209-F7-20
	2.5	-	-	04075	04075MS124779	MS21209-F7-25
	3	-	-	04076	04076MS124819	MS21209-F7-30



Recoil® Part Numbers Cross Reference - Tanged and Tangless®

Unified Fine - Free Running Series

Thread Size	Nominal Length (in Dia.)	Tangless		Tanged		
		Recoil Part Number	NA/NAS Tangless Part Number	Recoil Part Number	Recoil MA Part Number	SAE MA Part Number
1/2 - 20	1	-	-	04082	04082MS124660	MS21209-F8-10
	1.5	-	-	04083	04083MS124700	MS21209-F8-15
	2	-	-	04084	04084MS124740	MS21209-F8-20
	2.5	-	-	04085	04085MS124780	MS21209-F8-25
	3	-	-	04086	04086MS124820	MS21209-F8-30
9/16 - 18	1	-	-	04092	04092MS124661	MS21209-F9-10
	1.5	-	-	04093	04093MS124701	MS21209-F9-15
	2	-	-	04094	04094MS124741	MS21209-F9-20
	2.5	-	-	04095	04095MS124781	MS21209-F9-25
	3	-	-	04096	04096MS124821	MS21209-F9-30
5/8 - 18	1	-	-	04102	04102MS124662	MS21209-F1010
	1.5	-	-	04103	04103MS124702	MS21209-F1015
	2	-	-	04104	04104MS124742	MS21209-F1020
	2.5	-	-	04105	04105MS124782	MS21209-F1025
	3	-	-	04106	04106MS124822	MS21209-F1030
3/4 - 16	1	-	-	04122	04122MS124663	MS21209-F1210
	1.5	-	-	04123	04123MS124703	MS21209-F1215
	2	-	-	04124	04124MS124743	MS21209-F1220
	2.5	-	-	04125	04125MS124783	MS21209-F1225
	3	-	-	04126	04126MS124823	MS21209-F1230
7/8 - 14	1	-	-	04142	04142MS124664	MS21209-F1410
	1.5	-	-	04143	04143MS124704	MS21209-F1415
	2	-	-	04144	04144MS124744	MS21209-F1420
	2.5	-	-	04145	04145MS124784	MS21209-F1425
	3	-	-	04146	04146MS124824	MS21209-F1430
1 - 12	1	-	-	04162	04162MS124651	MS21209-F1610
	1.5	-	-	04163	04163MS124691	MS21209-F1615
	2	-	-	04164	04164MS124731	MS21209-F1620
	2.5	-	-	04165	04165MS124771	MS21209-F1625
	3	-	-	04166	04166MS124811	MS21209-F1630
1-1/8 - 12	1	-	-	04182	04182MS124666	MS21209-F1810
	1.5	-	-	04183	04183MS124706	MS21209-F1815
	2	-	-	04184	04184MS124746	MS21209-F1820
	2.5	-	-	04185	04185MS124786	MS21209-F1825
	3	-	-	04186	04186MS124826	MS21209-F1830
1-1/4 - 12	1	-	-	04202	04202MS124667	MS21209-F2010
	1.5	-	-	04203	04203MS124707	MS21209-F2015
	2	-	-	04204	04204MS124747	MS21209-F2020
	2.5	-	-	04205	04250MS124787	MS21209-F2025
	3	-	-	04206	04206MS124827	MS21209-F2030
1-3/8 - 12	1	-	-	04222	04222MS124668	MS21209-F2210
	1.5	-	-	04223	04223MS124708	MS21209-F2215
	2	-	-	04224	04224MS124748	MS21209-F2220
	2.5	-	-	04225	04245MS124788	MS21209-F2225
	3	-	-	04226	04246MS124828	MS21209-F2230

Recoil® Part Numbers Cross Reference - Tanged and Tangless®

Unified Fine - Free Running Series

Thread Size	Nominal Length (in Dia.)	Tangless		Tanged		
		Recoil Part Number	NA/NAS Tangless Part Number	Recoil Part Number	Recoil MA Part Number	SAE MA Part Number
1-1/2 - 12	1	-	-	04242	04242MS124669	MS21209-F2410
	1.5	-	-	04243	04243MS124709	MS21209-F2415
	2	-	-	04244	04244MS124749	MS21209-F2420
	2.5	-	-	04245	04245MS124789	MS21209-F2425
	3	-	-	04246	04246MS124829	MS21209-F2430





Recoil® Locking Insert - Torque Values

Nominal Thread Size	Max Locking Torque	Min Break Away Torque
Unified Coarse - (UNC)		
2 (.086") - 56	20 oz.in	3 oz.in
3 (.099") - 48	32 oz.in	7 oz.in
4 (.112") - 40	48 oz.in	10 oz.in
5 (.125") - 40	75 oz.in	13 oz.in
6 (.138") - 32	6 lb.in	1.0 lb.in
8 (.164") - 32	9 lb.in	1.5 lb.in
10 (.190") - 24	13 lb.in	2.0 lb.in
12 (.216") - 24	24 lb.in	3.0 lb.in
1/4 (.2500") - 20	30 lb.in	4.5 lb.in
5/16 (.3125") - 18	60 lb.in	7.5 lb.in
3/8 (.3750") - 18	80 lb.in	12.0 lb.in
7/16 (.4375") - 14	100 lb.in	16.5 lb.in
1/2 (.5000") - 13	150 lb.in	24.0 lb.in
9/16 (.5625") - 12	200 lb.in	30.0 lb.in
5/8 (.6250") - 11	300 lb.in	40.0 lb.in
3/4 (.7500") - 10	400 lb.in	60.0 lb.in
7/8 (.8750") - 9	600 lb.in	82.0 lb.in
1 (1.0000") - 8	800 lb.in	110.0 lb.in
1 1/8 (1.1250") - 7	900 lb.in	137.0 lb.in
1 1/4 (1.2500") - 7	1000 lb.in	165.0 lb.in
1 3/8 (1.3750") - 6	1150 lb.in	185.0 lb.in
1 1/2 (1.5000") - 6	1350 lb.in	210.0 lb.in
Metric Coarse		
Nominal Thread Size	Max Locking Torque	Min Break Away Torque
M2.2 - 0.45	0.14 Nm	0.02 Nm
M2.5 - 0.45	0.22 Nm	0.05 Nm
M3 - 0.5	0.44 Nm	0.1 Nm
M3.5 - 0.6	0.68 Nm	0.12 Nm
M4 - 0.7	0.9 Nm	0.15 Nm
M5 - 0.8	1.6 Nm	0.3 Nm
M6 - 1	3 Nm	0.4 Nm
M7 - 1	4.4 Nm	0.6 Nm
M8 - 1.25	6 Nm	0.8 Nm
M10 - 1.5	10 Nm	1.4 Nm
M12 - 1.75	15 Nm	2.1 Nm
M14 - 2	23 Nm	3 Nm
M16 - 2	32 Nm	4.2 Nm
M18 - 2.5	42 Nm	5.5 Nm
M20 - 2.5	54 Nm	7 Nm
M22 - 2.5	70 Nm	9 Nm
M24 - 3	80 Nm	10.5 Nm
M27 - 3	95 Nm	12 Nm
M30 - 3.5	110 Nm	14 Nm
M33 - 3.5	125 Nm	15.5 Nm
M36 - 4	136 Nm	17.5 Nm
M39 - 4	150 Nm	19.5 Nm
M39 - 2	150 Nm	19.5 Nm

Nominal Thread Size	Max Locking Torque	Min Break Away Torque
Unified Fine - (UNF)		
3 (.099") - 56	32 oz.in	7oz.in
4 (.112") - 48	48 oz.in	10 oz.in
6 (.138") - 40	6 lb.in	1.0 lb.in
8 (.164") - 36	9 lb.in	1.5 lb.in
10 (.190") - 32	13lb.in	2.0 lb.in
1/4 (.2500") - 28	30 lb.in	3.5 lb.in
5/16 (.3125") - 24	60 lb.in	6.5 lb.in
3/8 (.3750") - 24	80 lb.in	9.5 lb.in
7/16 (.4375") - 20	100 lb.in	14.0 lb.in
1/2 (.5000") - 20	150 lb.in	18.0 lb.in
9/16 (.5625") - 18	200 lb.in	24.0 lb.in
5/8 (.6250") - 18	300 lb.in	32.0 lb.in
3/4 (.7500") - 16	400 lb.in	50.0 lb.in
7/8 (.8750") - 14	600 lb.in	70.0 lb.in
1 (1.0000") - 12	800 lb.in	90.0 lb.in
1 1/8 (1.1250") - 12	900 lb.in	117.0 lb.in
1 1/4 (1.2500") - 12	1000 lb.in	143.0 lb.in
1 3/8 (1.3750") - 12	1150 lb.in	165.0 lb.in
1 1/2 (1.5000") - 12	1350 lb.in	190.0 lb.in
Metric Fine		
Nominal Thread Size	Max Locking Torque	Min Break Away Torque
M8 - 1	6 Nm	0.8 Nm
M10 - 1	10 Nm	1.4 Nm
M10 - 1.25	10 Nm	1.4 Nm
M12 - 1.25	15 Nm	2.2 Nm
M12 - 1.5	15 Nm	2.2 Nm
M14 - 1.5	23 Nm	3 Nm
M16 - 1.5	32 Nm	4.2 Nm
M18 - 1.5	42 Nm	5.5 Nm
M20 - 1.5	54 Nm	7 Nm
M22 - 1.5	70 Nm	9 Nm
M18 - 2	42 Nm	5.5 Nm
M20 - 2	54 Nm	7 Nm
M22 - 2	67.5 Nm	9 Nm
M24 - 2	80 Nm	11 Nm
M27 - 2	95 Nm	12 Nm
M30 - 2	110 Nm	14 Nm
M33 - 2	125 Nm	16 Nm
M36 - 2	140 Nm	18 Nm
M36 - 3	140 Nm	18 Nm
M39 - 2	150 Nm	20 Nm
M39 - 3	150 Nm	20 Nm
To Convert From	To	Multiply by
N.m	lbf-in	8.850748
N.m	ozf-in	141.6119
lbf-in	N.m	0.1129848
ozf-in	N.m	0.0070615

Recoil® Part Numbers Cross Reference - Tanged and Tangless®

Metric - Locking Series

Thread Size	Nominal Length (in Dia.)	Tangless		Tanged		
		Recoil Part Number	NA/NAS Tangless Part Number	Recoil Part Number	Recoil MA Part Number	SAE MA Part Number
M2.2 - 0.45	1	-	-	15012	15012MA	MA3329-100
	1.5	-	-	15013	15013MA	MA3329-150
	2	-	-	15014	15014MA	MA3329-200
	2.5	-	-	15015	15015MA	MA3329-250
	3	-	-	15016	15016MA	MA3329-300
M2.5 - 0.45	1	TL15252	NA0276M2AL-10	15252	15252MA	MA3329-101
	1.5	TL15253	NA0276M2AL-15	15253	15253MA	MA3329-151
	2	TL15254	NA0276M2AL-20	15254	15254MA	MA3329-201
	2.5	TL15255	NA0276M2AL-25	15255	15255MA	MA3329-251
	3	TL15256	NA0276M2AL-30	15256	15256MA	MA3329-301
M3 - 0.5	1	TL15032	NA0276M3L-10	15032	15032MA	MA3329-102
	1.5	TL15033	NA0276M3L-15	15033	15033MA	MA3329-152
	2	TL15034	NA0276M3L-20	15034	15034MA	MA3329-202
	2.5	TL15035	NA0276M3L-25	15035	15035MA	MA3329-252
	3	TL15036	NA0276M3L-30	15036	15036MA	MA3329-302
M3.5 - 0.6	1	-	-	15352	15352MA	MA3329-103
	1.5	-	-	15353	15353MA	MA3329-153
	2	-	-	15354	15354MA	MA3329-203
	2.5	-	-	15355	15355MA	MA3329-253
	3	-	-	15356	15356MA	MA3329-303
M4 - 0.7	1	TL15042	NA0276M4L-10	15042	15042MA	MA3329-104
	1.5	TL15043	NA0276M4L-15	15043	15043MA	MA3329-154
	2	TL15044	NA0276M4L-20	15044	15044MA	MA3329-204
	2.5	TL15045	NA0276M4L-25	15045	15045MA	MA3329-254
	3	TL15046	NA0276M4L-30	15046	15046MA	MA3329-304
M5 - 0.8	1	TL15052	NA0276M5L-10	15052	15052MA	MA3329-105
	1.5	TL15053	NA0276M5L-15	15053	15053MA	MA3329-155
	2	TL15054	NA0276M5L-20	15054	15054MA	MA3329-205
	2.5	TL15055	NA0276M5L-25	15055	15055MA	MA3329-255
	3	TL15056	NA0276M5L-30	15056	15056MA	MA3329-305
M6 - 1	1	TL15062	NA0276M6L-10	15062	15062MA	MA3329-106
	1.5	TL15063	NA0276M6L-15	15063	15063MA	MA3329-156
	2	TL15064	NA0276M6L-20	15064	15064MA	MA3329-206
	2.5	TL15065	NA0276M6L-25	15065	15065MA	MA3329-256
	3	TL15066	NA0276M6L-30	15066	15066MA	MA3329-306

Recoil® Part Numbers Cross Reference - Tanged and Tangless®

Metric - Locking Series

Thread Size	Nominal Length (in Dia.)	Tangless		Tanged		
		Recoil Part Number	NA/NAS Tangless Part Number	Recoil Part Number	Recoil MA Part Number	SAE MA Part Number
M7 - 1	1	-	-	15072	15072MA	MA3329-107
	1.5	-	-	15073	15073MA	MA3329-157
	2	-	-	15074	15074MA	MA3329-207
	2.5	-	-	15075	15075MA	MA3329-257
	3	-	-	15076	15076MA	MA3329-307
M8 - 1	1	-	-	17082	17082MA	MA3329-108
	1.5	-	-	17083	17083MA	MA3329-158
	2	-	-	17084	17084MA	MA3329-208
	2.5	-	-	17085	17085MA	MA3329-258
	3	-	-	17086	17086MA	MA3329-308
M8 - 1.25	1	TL15082	NA0276M8L-10	15082	15082MA	MA3329-109
	1.5	TL15083	NA0276M8L-15	15083	15083MA	MA3329-159
	2	TL15084	NA0276M8L-20	15084	15084MA	MA3329-209
	2.5	TL15085	NA0276M8L-25	15085	15085MA	MA3329-259
	3	TL15086	NA0276M8L-30	15086	15086MA	MA3329-309
M10 - 1.25	1	-	-	17102	17102MA	MA3329-110
	1.5	-	-	17103	17103MA	MA3329-160
	2	-	-	17104	17104MA	MA3329-210
	2.5	-	-	17105	17105MA	MA3329-260
	3	-	-	17106	17106MA	MA3329-310
M10 - 1.5	1	TL15102	NA0276M10L-10	15102	15102MA	MA3329-111
	1.5	TL15103	NA0276M10L-15	15103	15103MA	MA3329-161
	2	TL15104	NA0276M10L-20	15104	15104MA	MA3329-211
	2.5	TL15105	NA0276M10L-25	15105	15105MA	MA3329-261
	3	TL15106	NA0276M10L-30	15106	15106MA	MA3329-311
M12 - 1.25	1	-	-	18122	18122MA	MA3329-112
	1.5	-	-	18123	18123MA	MA3329-162
	2	-	-	18124	18124MA	MA3329-212
	2.5	-	-	18125	18125MA	MA3329-262
	3	-	-	18126	18126MA	MA3329-312
M12 - 1.5	1	-	-	07122	07122MA	MA3329-113
	1.5	-	-	07123	07123MA	MA3329-163
	2	-	-	07124	07124MA	MA3329-213
	2.5	-	-	07125	07125MA	MA3329-263
	3	-	-	07126	07126MA	MA3329-313
M12 - 1.75	1	TL15122	NA0276M12L-10	15122	15122MA	MA3329-114
	1.5	TL15123	NA0276M12L-15	15123	15123MA	MA3329-164
	2	TL15124	NA0276M12L-20	15124	15124MA	MA3329-214
	2.5	TL15125	NA0276M12L-25	15125	15125MA	MA3329-264
	3	TL15126	NA0276M12L-30	15126	15126MA	MA3329-314

Recoil® Part Numbers Cross Reference - Tanged and Tangless®

Metric - Locking Series

Thread Size	Nominal Length (in Dia.)	Tangless		Tanged		
		Recoil Part Number	NA/NAS Tangless Part Number	Recoil Part Number	Recoil MA Part Number	SAE MA Part Number
M14 - 1.5	1	-	-	17142	17142MA	MA3329-115
	1.5	-	-	17143	17143MA	MA3329-165
	2	-	-	17144	17144MA	MA3329-215
	2.5	-	-	17145	17145MA	MA3329-265
	3	-	-	17146	17146MA	MA3329-315
M14 - 2	1	-	-	15142	15142MA	MA3329-116
	1.5	-	-	15143	15143MA	MA3329-166
	2	-	-	15144	15144MA	MA3329-216
	2.5	-	-	15145	15145MA	MA3329-266
	3	-	-	15146	15146MA	MA3329-316
M16 - 1.5	1	-	-	17162	17162MA	MA3329-117
	1.5	-	-	17163	17163MA	MA3329-167
	2	-	-	17164	17164MA	MA3329-217
	2.5	-	-	17165	17165MA	MA3329-267
	3	-	-	17166	17166MA	MA3329-317
M16 - 2	1	-	-	15162	15162MA	MA3329-118
	1.5	-	-	15163	15163MA	MA3329-168
	2	-	-	15164	15164MA	MA3329-218
	2.5	-	-	15165	15165MA	MA3329-268
	3	-	-	15166	15166MA	MA3329-318
M18 - 1.5	1	-	-	18182	18182MA	MA3329-119
	1.5	-	-	18183	18183MA	MA3329-169
	2	-	-	18184	18184MA	MA3329-219
	2.5	-	-	18185	18185MA	MA3329-269
	3	-	-	18186	18186MA	MA3329-319
M18 - 2	1	-	-	17182	17182MA	MA3329-120
	1.5	-	-	17183	17183MA	MA3329-170
	2	-	-	17184	17184MA	MA3329-220
	2.5	-	-	17185	17185MA	MA3329-270
	3	-	-	17186	17186MA	MA3329-320
M18 - 2.5	1	-	-	15182	15182MA	MA3329-121
	1.5	-	-	15183	15183MA	MA3329-171
	2	-	-	15184	15184MA	MA3329-221
	2.5	-	-	15185	15185MA	MA3329-271
	3	-	-	15186	15186MA	MA3329-321
M20 - 1.5	1	-	-	18202	18202MA	MA3329-122
	1.5	-	-	18203	18203MA	MA3329-172
	2	-	-	18204	18204MA	MA3329-222
	2.5	-	-	18205	18205MA	MA3329-272
	3	-	-	18206	18206MA	MA3329-322



Recoil® Part Numbers Cross Reference - Tanged and Tangless®

Metric - Locking Series

Thread Size	Nominal Length (in Dia.)	Tangless		Tanged		
		Recoil Part Number	NA/NAS Tangless Part Number	Recoil Part Number	Recoil MA Part Number	SAE MA Part Number
M20 - 2	1	-	-	17202	17202MA	MA3329-123
	1.5	-	-	17203	17203MA	MA3329-173
	2	-	-	17204	17204MA	MA3329-223
	2.5	-	-	17205	17205MA	MA3329-273
	3	-	-	17206	17206MA	MA3329-323
M20 - 2.5	1	-	-	15202	15202MA	MA3329-124
	1.5	-	-	15203	15203MA	MA3329-174
	2	-	-	15204	15204MA	MA3329-224
	2.5	-	-	15205	15205MA	MA3329-274
	3	-	-	15206	15206MA	MA3329-324
M22 - 1.5	1	-	-	18222	18222MA	MA3329-125
	1.5	-	-	18223	18223MA	MA3329-175
	2	-	-	18224	18224MA	MA3329-225
	2.5	-	-	18225	18225MA	MA3329-275
	3	-	-	18226	18226MA	MA3329-325
M22 - 2	1	-	-	17222	17222MA	MA3329-126
	1.5	-	-	17223	17223MA	MA3329-176
	2	-	-	17224	17224MA	MA3329-226
	2.5	-	-	17225	17225MA	MA3329-276
	3	-	-	17226	17226MA	MA3329-326
M22 - 2.5	1	-	-	15222	15222MA	MA3329-127
	1.5	-	-	15223	15223MA	MA3329-177
	2	-	-	15224	15224MA	MA3329-227
	2.5	-	-	15225	15225MA	MA3329-277
	3	-	-	15226	15226MA	MA3329-327
M24 - 2	1	-	-	17242	17242MA	MA3329-128
	1.5	-	-	17243	17243MA	MA3329-178
	2	-	-	17244	17244MA	MA3329-228
	2.5	-	-	17245	17245MA	MA3329-278
	3	-	-	17246	17246MA	MA3329-328
M24 - 3	1	-	-	15242	15242MA	MA3329-129
	1.5	-	-	15243	15243MA	MA3329-179
	2	-	-	15244	15244MA	MA3329-229
	2.5	-	-	15245	15245MA	MA3329-279
	3	-	-	15246	15246MA	MA3329-329

Recoil® Part Numbers Cross Reference - Tanged and Tangless®

Metric - Locking Series

Thread Size	Nominal Length (in Dia.)	Tangless		Tanged		
		Recoil Part Number	NA/NAS Tangless Part Number	Recoil Part Number	Recoil MA Part Number	SAE MA Part Number
M27 - 2	1	-	-	17272	17272MA	MA3329-130
	1.5	-	-	17273	17273MA	MA3329-180
	2	-	-	17274	17274MA	MA3329-230
	2.5	-	-	17275	17275MA	MA3329-280
	3	-	-	17276	17276MA	MA3329-330
M27 - 3	1	-	-	15272	15272MA	MA3329-131
	1.5	-	-	15273	15273MA	MA3329-181
	2	-	-	15274	15274MA	MA3329-231
	2.5	-	-	15275	15275MA	MA3329-281
	3	-	-	15276	15276MA	
M30 - 2	1	-	-	17302	17302MA	MA3329-132
	1.5	-	-	17303	17303MA	MA3329-182
	2	-	-	17304	17304MA	MA3329-232
	2.5	-	-	17305	17305MA	MA3329-282
	3	-	-	17306	17306MA	MA3329-332
M30 - 3	1	-	-	15302-3	15302-3MA	MA3329-133
	1.5	-	-	15303-3	15303-3MA	MA3329-183
	2	-	-	15304-3	15304-3MA	MA3329-233
	2.5	-	-	15305-3	15305-3MA	MA3329-283
	3	-	-	15360-3	15360-3MA	MA3329-333
M30 - 3.5	1	-	-	15302	-	-
	1.5	-	-	15303	-	-
	2	-	-	15304	-	-
	2.5	-	-	15305	-	-
	3	-	-	15306	-	-



Recoil® Part Numbers Cross Reference - Tanged and Tangless®

Metric - Locking Series

Thread Size	Nominal Length (in Dia.)	Tangless		Tanged		
		Recoil Part Number	NA/NAS Tangless Part Number	Recoil Part Number	Recoil MA Part Number	SAE MA Part Number
M33 - 2	1	-	-	17332	17332MA	MA3329-134
	1.5	-	-	17333	17333MA	MA3329-184
	2	-	-	17334	17334MA	MA3329-234
	2.5	-	-	17335	17335MA	MA3329-284
	3	-	-	17336	17336MA	MA3329-334
M33 - 3	1	-	-	17332-3	17332-3MA	MA3329-135
	1.5	-	-	17333-3	17333-3MA	MA3329-185
	2	-	-	17334-3	17334-3MA	MA3329-235
	2.5	-	-	17335-3	17335-3MA	MA3329-285
	3	-	-	17336-3	17336-3MA	MA3329-335
M33 - 3.5	1	-	-	15332	15332MA	-
	1.5	-	-	15333	15333MA	-
	2	-	-	15334	15334MA	-
	2.5	-	-	15335	-	-
	3	-	-	15336	-	-
M36 - 1.5	1	-	-	18362	-	-
	1.5	-	-	18363	-	-
	2	-	-	18364	-	-
	2.5	-	-	18365	-	-
	3	-	-	18366	-	-
M36 - 2	1	-	-	07362-2	07362-2MA	MA3279-136
	1.5	-	-	07363-2	07363-2MA	MA3279-186
	2	-	-	07364-2	07364-2MA	MA3279-236
	2.5	-	-	07365-2	07365-2MA	MA3279-286
	3	-	-	07366-2	07366-2MA	MA3279-336
M36 - 3	1	-	-	17362	17362MA	MA3329-137
	1.5	-	-	17363	17363MA	MA3329-187
	2	-	-	17364	17364MA	MA3329-237
	2.5	-	-	17365	17365MA	MA3329-287
	3	-	-	17366	17366MA	MA3329-337
M36 - 4	1	-	-	15362	-	-
	1.5	-	-	15363	-	-
	2	-	-	15364	-	-
	2.5	-	-	15365	-	-
	3	-	-	15366	-	-
M39 - 2	1	-	-	18392	-	MA3329-138
	1.5	-	-	18393	-	MA3329-188
	2	-	-	18394	-	MA3329-238
	2.5	-	-	18395	-	MA3329-288
	3	-	-	18396	-	MA3329-338

Recoil® Part Numbers Cross Reference - Tanged and Tangless®

Metric - Locking Series

Thread Size	Nominal Length (in Dia.)	Tangless		Tanged		
		Recoil Part Number	NA/NAS Tangless Part Number	Recoil Part Number	Recoil MA Part Number	SAE MA Part Number
M39 - 3	1	-	-	17392	07392MA	MA3329-139
	1.5	-	-	17393	07393MA	MA3329-189
	2	-	-	17394	07394MA	MA3329-239
	2.5	-	-	17394	07394MA	MA3329-289
	3	-	-	17396	07396MA	MA3329-339
M39 - 4	1	-	-	15392	15392MA	-
	1.5	-	-	15393	15393MA	-
	2	-	-	15394	15394MA	-
	2.5	-	-	15395	-	-
	3	-	-	15396	-	-



Recoil® Part Numbers Cross Reference - Tanged and Tangless®

Unified Coarse - Locking Series

Thread Size	Nominal Length (in Dia.)	Tangless		Tanged	
		Recoil Part Number	NA/NAS Tangless Part Number	Recoil Part Number	SAE MS Part Number
#2 - 56	1	TL13522	NAS1130-02L-10	13522	MS21209-C0210
	1.5	TL13523	NAS1130-02L-15	13523	MS21209-C0215
	2	TL13524	NAS1130-0L-20	13524	MS21209-C0220
	2.5	TL13525	NAS1130-0L-25	13525	MS21209-C0225
	3	TL13526	NAS1130-0L-30	13526	MS21209-C0230
#3 - 48	1	-	-	13532	MS21209-C0310
	1.5	-	-	13533	MS21209-C0315
	2	-	-	13534	MS21209-C0320
	2.5	-	-	13535	MS21209-C0325
	3	-	-	13536	MS21209-C0330
#4 - 40	1	TL13542	NAS1130-04L-10	13542	MS21209-C0410
	1.5	TL13543	NAS1130-04L-15	13543	MS21209-C0415
	2	TL13544	NAS1130-04L-20	13544	MS21209-C0420
	2.5	TL13545	NAS1130-04L-25	13545	MS21209-C0425
	3	TL13546	NAS1130-04L-30	13546	MS21209-C0430
#5 - 40	1	-	-	13552	MS21209-C0510
	1.5	-	-	13553	MS21209-C0515
	2	-	-	13554	MS21209-C0520
	2.5	-	-	13555	MS21209-C0525
	3	-	-	13556	MS21209-C0530
#6 - 32	1	TL13562	NAS1130-06L-10	13562	MS21209-C0610
	1.5	TL13563	NAS1130-06L-15	13563	MS21209-C0615
	2	TL13564	NAS1130-06L-20	13564	MS21209-C0620
	2.5	TL13565	NAS1130-06L-25	13565	MS21209-C0625
	3	TL13566	NAS1130-06L-30	13566	MS21209-C0630
#8 - 32	1	TL13582	NAS1130-08L-10	13582	MS21209-C0810
	1.5	TL13583	NAS1130-08L-15	13583	MS21209-C0815
	2	TL13584	NAS1130-08L-20	13584	MS21209-C0820
	2.5	TL13585	NAS1130-08L-25	13585	MS21209-C0825
	3	TL13586	NAS1130-08L-30	13586	MS21209-C0830
#10 - 24	1	TL13602	NAS1130-3CL-10	13602	MS21209-C1-10
	1.5	TL13603	NAS1130-3CL-15	13603	MS21209-C1-15
	2	TL13604	NAS1130-3CL-20	13604	MS21209-C1-20
	2.5	TL13605	NAS1130-3CL-25	13605	MS21209-C1-25
	3	TL13606	NAS1130-3CL-30	13606	MS21209-C1-30
#12 - 24	1	-	-	13622	MS21209-C2-10
	1.5	-	-	13623	MS21209-C2-15
	2	-	-	13624	MS21209-C2-20
	2.5	-	-	13625	MS21209-C2-25
	3	-	-	13626	MS21209-C2-30
1/4 - 20	1	TL13042	NAS1130-4L-10	13042	MS21209-C4-10
	1.5	TL13043	NAS1130-4L-15	13043	MS21209-C4-15
	2	TL13044	NAS1130-4L-20	13044	MS21209-C4-20
	2.5	TL13045	NAS1130-4L-25	13045	MS21209-C4-25
	3	TL13046	NAS1130-4L-30	13046	MS21209-C4-30

Recoil® Part Numbers Cross Reference - Tanged and Tangless®

Unified Coarse - Locking Series

Thread Size	Nominal Length (in Dia.)	Tangless		Tanged	
		Recoil Part Number	NA/NAS Tangless Part Number	Recoil Part Number	SAE MS Part Number
5/16 - 18	1	TL13052	NAS1130-5CL-10	13052	MS21209-C5-10
	1.5	TL13053	NAS1130-5CL-15	13053	MS21209-C5-15
	2	TL13054	NAS1130-5CL-20	13054	MS21209-C5-20
	2.5	TL13055	NAS1130-5CL-25	13055	MS21209-C5-25
	3	TL13056	NAS1130-5CL-30	13056	MS21209-C5-30
3/8 - 16	1	TL13062	NAS1130-6CL-10	13062	MS21209-C6-10
	1.5	TL13063	NAS1130-6CL-15	13063	MS21209-C6-15
	2	TL13064	NAS113-06CL-20	13064	MS21209-C6-20
	2.5	TL13065	NAS113-06CL-25	13065	MS21209-C6-25
	3	TL13066	NAS113-06CL-30	13066	MS21209-C6-30
7/16 - 14	1	-	-	13072	MS21209-C7-10
	1.5	-	-	13073	MS21209-C7-15
	2	-	-	13074	MS21209-C87-20
	2.5	-	-	13075	MS21209-C7-25
	3	-	-	13076	MS21209-C7-30
1/2 - 13	1	TL03082	-	13082	MS21209-C8-10
	1.5	TL03083	-	13083	MS21209-C8-15
	2	TL03084	-	13084	MS21209-C8-20
	2.5	TL03085	-	13085	MS21209-C8-25
	3	-	-	13086	MS21209-C8-30
9/16 - 12	1	-	-	13092	MS21209-C9-10
	1.5	-	-	13093	MS21209-C--15
	2	-	-	13094	MS21209-C9-20
	2.5	-	-	13095	MS21209-C9-25
	3	-	-	13096	MS21209-C9-30
5/8 - 11	1	-	-	13102	MS21209-C1010
	1.5	-	-	13103	MS21209-C105
	2	-	-	13104	MS21209-C1020
	2.5	-	-	13105	MS21209-C1025
	3	-	-	13106	MS21209-C1030
3/4 - 10	1	-	-	13122	MS21209-C1210
	1.5	-	-	13123	MS21209-C1215
	2	-	-	13124	MS21209-C1220
	2.5	-	-	13125	MS21209-C1225
	3	-	-	13126	MS21209-C1230
7/8 - 9	1	-	-	13142	MS21209-C1410
	1.5	-	-	13143	MS21209-C1415
	2	-	-	13144	MS21209-C1420
	2.5	-	-	13145	MS21209-C1425
	3	-	-	13146	MS21209-C1430
1 - 8	1	-	-	13162	MS21209-C1610
	1.5	-	-	13163	MS21209-C1615
	2	-	-	13164	MS21209-C1620
	2.5	-	-	13165	MS21209-C1625
	3	-	-	13166	MS21209-C1630



Recoil® Part Numbers Cross Reference - Tanged and Tangless®

Unified Coarse - Locking Series

Thread Size	Nominal Length (in Dia.)	Tangless		Tanged	
		Recoil Part Number	NA/NAS Tangless Part Number	Recoil Part Number	SAE MS Part Number
1 1/8 - 7	1	-	-	13182	MS21209-C1810
	1.5	-	-	13183	MS21209-C1815
	2	-	-	13184	MS21209-C1820
	2.5	-	-	13185	MS21209-C1825
	3	-	-	13186	MS21209-C1830
1 1/4 - 7	1	-	-	13202	MS21209-C2010
	1.5	-	-	13203	MS21209-C2015
	2	-	-	13204	MS21209-C2020
	2.5	-	-	13205	MS21209-C2025
	3	-	-	13206	MS21209-C2030
1 3/8 - 6	1	-	-	13222	MS21209-C2210
	1.5	-	-	13223	MS21209-C2215
	2	-	-	13224	MS21209-C2220
	2.5	-	-	13225	MS21209-C2225
	3	-	-	13226	MS21209-C2230
1 1/2 - 6	1	-	-	13242	MS21209-C2410
	1.5	-	-	13243	MS21209-C2415
	2	-	-	13244	MS21209-C2420
	2.5	-	-	13245	MS21209-C2425
	3	-	-	13246	MS21209-C2430

Recoil® Part Numbers Cross Reference - Tanged and Tangless®

Unified Fine - Locking Series

Thread Size	Nominal Length (in Dia.)	Tangless		Tanged	
		Recoil Part Number	NA/NAS Tangless Part Number	Recoil Part Number	SAE MS Part Number
#3 - 56	1	-	-	14532	MS21209-F0310
	1.5	-	-	14533	MS21209-F0315
	2	-	-	14534	MS21209-F0320
	2.5	-	-	14535	MS21209-F0325
	3	-	-	14536	MS21209-F0330
#4 - 48	1	-	-	14542	MS21209-F0410
	1.5	-	-	14543	MS21209-F0415
	2	-	-	14544	MS21209-F0420
	2.5	-	-	14545	MS21209-F0425
	3	-	-	14546	MS21209-F0430
#6 - 40	1	-	-	14562	MS21209-F0610
	1.5	-	-	14563	MS21209-F0615
	2	-	-	14564	MS21209-F0620
	2.5	-	-	14565	MS21209-F0625
	3	-	-	14566	MS21209-F0630
#8 - 36	1	-	-	14582	MS21209-F0810
	1.5	-	-	14583	MS21209-F0815
	2	-	-	14584	MS21209-F0820
	2.5	-	-	14585	MS21209-F0825
	3	-	-	14586	MS21209-F0830
#10 - 32	1	TL14602	NAS1130-3L-10	14602	MS21209-F1-10
	1.5	TL14603	NAS1130-3L-15	14603	MS21209-F1-15
	2	TL14604	NAS1130-3L-20	14604	MS21209-F1-20
	2.5	TL14605	NAS1130-3L-25	14605	MS21209-F1-25
	3	TL14606	NAS1130-3L-30	14606	MS21209-F1-30
1/4 - 28	1	TL14042	NAS1130-4FL-10	14042	MS21209-F4-10
	1.5	TL14043	NAS1130-4FL-15	14043	MS21209-F4-15
	2	TL14044	NAS1130-4FL-20	14044	MS21209-F4-20
	2.5	TL14045	NAS1130-4FL-25	14045	MS21209-F4-25
	3	TL14046	NAS1130-4FL-30	14046	MS21209-F4-30
5/16 - 24	1	TL14052	NAS1130-5FL-10	14052	MS21209-F5-10
	1.5	TL14053	NAS1130-5FL-15	14053	MS21209-F5-15
	2	TL14054	NAS1130-5FL-20	14054	MS21209-F5-20
	2.5	TL14055	NAS1130-5FL-25	14055	MS21209-F5-25
	3	TL14056	NAS1130-5FL-30	14056	MS21209-F5-30
3/8 - 24	1	TL14062	NAS1130-6FL-10	14062	MS21209-F6-10
	1.5	TL14063	NAS1130-6FL-15	14063	MS21209-F6-15
	2	TL14064	NAS1130-6FL-20	14064	MS21209-F6-20
	2.5	TL14065	NAS1130-6FL-25	14065	MS21209-F6-25
	3	TL14066	NAS1130-6FL-30	14066	MS21209-F6-30
7/16 - 20	1	-	-	14072	MS21209-F7-10
	1.5	-	-	14073	MS21209-F7-15
	2	-	-	14074	MS21209-F7-20
	2.5	-	-	14075	MS21209-F7-25
	3	-	-	14076	MS21209-F7-30



Recoil® Part Numbers Cross Reference - Tanged and Tangless®

Unified Fine - Locking Series

Thread Size	Nominal Length (in Dia.)	Tangless		Tanged	
		Recoil Part Number	NA/NAS Tangless Part Number	Recoil Part Number	SAE MS Part Number
1/2 - 20	1	-	-	14082	MS21209-F8-10
	1.5	-	-	14083	MS21209-F8-15
	2	-	-	14084	MS21209-F8-20
	2.5	-	-	14085	MS21209-F8-25
	3	-	-	14086	MS21209-F8-30
9/16 - 18	1	-	-	14092	MS21209-F9-10
	1.5	-	-	14093	MS21209-F9-15
	2	-	-	14094	MS21209-F9-20
	2.5	-	-	14095	MS21209-F9-25
	3	-	-	14096	MS21209-F9-30
5/8 - 18	1	-	-	14102	MS21209-F1010
	1.5	-	-	14103	MS21209-F1015
	2	-	-	10104	MS21209-F1020
	2.5	-	-	14105	MS21209-F1025
	3	-	-	14106	MS21209-F1030
3/4 - 16	1	-	-	14122	MS21209-F1210
	1.5	-	-	14123	MS21209-F1215
	2	-	-	14124	MS21209-F1220
	2.5	-	-	14125	MS21209-F1225
	3	-	-	14126	MS21209-F1230
7/8 - 14	1	-	-	14142	MS21209-F1410
	1.5	-	-	14143	MS21209-F1415
	2	-	-	14144	MS21209-F1420
	2.5	-	-	14145	MS21209-F1425
	3	-	-	14146	MS21209-F1430
1 - 12	1	-	-	14162	MS21209-F1610
	1.5	-	-	14163	MS21209-F1615
	2	-	-	14164	MS21209-F1620
	2.5	-	-	14165	MS21209-F1625
	3	-	-	14166	MS21209-F1630
1-1/8 - 12	1	-	-	14182	MS21209-F1810
	1.5	-	-	14183	MS21209-F1815
	2	-	-	14184	MS21209-F1820
	2.5	-	-	14185	MS21209-F1825
	3	-	-	14186	MS21209-F1830
1-1/4 - 12	1	-	-	14202	MS21209-F2010
	1.5	-	-	14203	MS21209-F2015
	2	-	-	14204	MS21209-F2020
	2.5	-	-	14205	MS21209-F2025
	3	-	-	14206	MS21209-F2030
1-3/8 - 12	1	-	-	14222	MS21209-F2210
	1.5	-	-	14223	MS21209-F2215
	2	-	-	14224	MS21209-F2220
	2.5	-	-	14225	MS21209-F2225
	3	-	-	14226	MS21209-F2230

Recoil® Part Numbers Cross Reference - Tanged and Tangless®

Unified Fine - Locking Series

Thread Size	Nominal Length (in Dia.)	Tangless		Tanged	
		Recoil Part Number	NA/NAS Tangless Part Number	Recoil Part Number	SAE MS Part Number
1-1/2 - 12	1	-	-	14242	MS21209-F2410
	1.5	-	-	14243	MS21209-F2415
	2	-	-	14244	MS21209-F2420
	2.5	-	-	14245	MS21209-F2425
	3	-	-	14246	MS21209-F2430



Recoil® Strip-Feed Inserts

To complete the Recoil power installation tools, Recoil has inserts available on strip (M2.5-M12, #2-5/16) to optimize production with increased installation cycles and reduced operator fatigue. Recoil strip feed inserts provide many advantages such as minimized handling costs, faster, more economical assembly and positive inventory control. When used in combination with Recoil pneumatic installation tooling, each insert is retained in plastic strip which is passed through a slot in the front end assembly nozzle, indexing the insert to the installation mandrel. Recoil Strip-Feed inserts are available in most common thread diameters and lengths in addition to the various surface finishes which are available on standard Recoil bulk inserts. The table shows some commonly supplied Recoil Strip-Feed inserts and defines the typical quantity of inserts supplied per reel for each given thread size. Additional insert diameters and lengths may be available to special order.



Recoil Strip Feed Part Numbers - Tanged and Tangless®

Metric

Thread Size	Magazined on Reels Dia 200mm							
	Nominal Length (in Dia.)	Tangless		Tanged				No. of Inserts
		Strip Feed Part Number Free Running	Strip Feed Part Number Locking	Strip Feed Part Number Free Running	Strip Feed Part Number Locking	Strip Feed Part Number MA Free Running	Strip Feed Part Number MA Locking	
M2.2 - 0.45	1	-	-	05012SF	15012SF	05012MASF	-	1000
	1.5	-	-	05013SF	15013SF	05013MASF	-	1000
	2.0	-	-	05014SF	15014SF	05014MASF	-	1000
M2.5 - 0.45	1	TL05252SF	TL15252SF	05252SF	15252SF	05252MASF	-	1000
	1.5	TL05253SF	TL15253SF	05253SF	15253SF	05253MASF	-	1000
	2.0	TL05254SF	TL15254SF	05254SF	15254SF	05254MASF	-	1000
	2.5	TL05255SF	TL15255SF	05255SF	15255SF	05255MASF	-	1000
M3 - 0.5	1	TL05032SF	TL15032SF	05032SF	15032SF	05032MASF	-	1000
	1.5	TL05033SF	TL15033SF	05033SF	15033SF	05033MASF	-	1000
M3.5 - 0.6	1	TL05352SF	TL15352SF	05352SF	15352SF	05352MASF	-	1000
	1.5	TL05353SF	TL15353SF	05353SF	15353SF	05353MASF	-	1000
M4 - 0.7	1	TL05042SF	TL15042SF	05042SF	15042SF	05042MASF	-	1000
M6 - 1.0	1	TL05062SF	TL15062SF	05062SF	15062SF	05062MASF	-	500

Recoil® Strip Feed Part Numbers - Tanged and Tangless®

Metric

Thread Size	Nominal Length (in Dia.)	Tangless		Magazined on Reels Dia 290mm				No. of Inserts
		Strip Feed Part Number Free Running	Strip Feed Part Number Locking	Strip Feed Part Number Free Running	Strip Feed Part Number Locking	Strip Feed Part Number MA Free Running	Strip Feed Part Number MA Locking	
M3 - 0.5	2	TL05034SF	TL15034SF	05034SF	15034SF	-	15034MASF	1000
	2.5	TL05035SF	TL15035SF	05035SF	15035SF	-	15035MASF	1000
M4 - 0.7	1.5	TL05043SF	TL15043SF	05043SF	15043SF	-	15043MASF	1000
	2	TL05044SF	TL15044SF	05044SF	15044SF	-	15044MASF	1000
	2.5	TL05045SF	TL15045SF	05045SF	15045SF	-	15045MASF	500
M5 - 0.8	3	TL05046SF	TL15046SF	05046SF	15046SF	-	15046MASF	500
	1	TL05052SF	TL15052SF	05052SF	15052SF	-	15052MASF	1000
	1.5	TL05053SF	TL15053SF	05053SF	15053SF	-	15053MASF	500
	2	TL05054SF	TL15054SF	05054SF	15054SF	-	15054MASF	500
M6 - 1.0	2.5	TL05055SF	TL15055SF	05055SF	15055SF	-	15055MASF	500
	1.5	TL05063SF	TL15063SF	05063SF	15063SF	-	15064MASF	500
	2	TL05064SF	TL15064SF	05064SF	15064SF	-	15063MASF	500
M8 - 1	2.5	TL05065SF	TL15065SF	05065SF	15065SF	-	15065MASF	500
	1	-	-	07082SF	17082SF	-	17082MASF	500
	1.5	-	-	07083SF	17083SF	-	17083MASF	500
M8 - 1.25	2	-	-	07084SF	17084SF	-	17084MASF	500
	1	TL05082SF	TL15082SF	05082SF	15082SF	15082SF	05082MASF	500
M12 - 1.75	1	05122SF	15122SF	05122SF	15122SF	05122MASF	15122MASF	125
	1.5	05123SF	15123SF	05123SF	15123SF	05123MASF	15123MASF	125
	2.0	05124SF	15124SF	05124SF	15124SF	05124MASF	15124MASF	125

Recoil Strip Feed Part Numbers - Tanged and Tangless

Metric

Thread Size	Nominal Length (in Dia.)	Tangless		Magazined on Reels Dia 385mm				No. of Inserts
		Strip Feed Part Number Free Running	Strip Feed Part Number Locking	Strip Feed Part Number Free Running	Strip Feed Part Number Locking	Strip Feed Part Number MA Free Running	Strip Feed Part Number MA Locking	
M8 - 1.25	1.5	TL05083SF	TL15083SF	05083SF	15083SF	-	15083MASF	500
	2	TL05084SF	TL15084SF	05084SF	15084SF	-	15084MASF	500
M10 - 1	1	-	-	08102SF	18102SF	-	18102MASF	500
	1.5	-	-	08103SF	18103SF	-	18103MASF	500
	2	-	-	08104SF	18104SF	-	18104MASF	500
M10 - 1.25	1	-	-	07102SF	17102SF	-	17102MASF	500
	1.5	-	-	07103SF	17103SF	-	17103MASF	500
	2	-	-	07104SF	17104SF	-	17104MASF	500
M10 - 1.5	1	TL05102SF	TL15102SF	05102SF	15102SF	-	15102MASF	500
	1.5	TL05103SF	TL15103SF	05103SF	15103SF	-	15103MASF	500
	2	TL05104SF	TL15104SF	05104SF	15104SF	-	15104MASF	500



Recoil® Strip Feed Part Numbers - Tanged and Tangless®

Unified

Thread Size	Magazined on Reels Dia 200mm							
	Nominal Length (in Dia.)	Tangless		Tanged				No. of Inserts
		Strip Feed Part Number Free Running	Strip Feed Part Number Locking	Strip Feed Part Number Free Running	Strip Feed Part Number Locking	Strip Feed Part Number MS Free Running	Strip Feed Part Number MS Locking	
#2 - 56	1	TL03522SF	TL13522SF	03522SF	13522SF	-	-	1000
	1.5	TL03523SF	TL13523SF	03523SF	13523SF	-	-	1000
	2	TL03524SF	TL13524SF	03524SF	13524SF	-	-	1000
#3 - 48	1	-	-	03532SF	13532SF	-	-	1000
	1.5	-	-	03533SF	13533SF	-	-	1000
	2	-	-	03534SF	13534SF	-	-	1000
#3 - 56	1	-	-	04532SF	14532SF	-	-	1000
	1.5	-	-	04533SF	14533SF	-	-	1000
	2	-	-	04534SF	14534SF	-	-	1000
#4 - 40	1	TL03542SF	TL13542SF	03542SF	13542SF	-	-	1000
	1.5	TL03543SF	TL13543SF	03543SF	13543SF	-	-	1000
	2	-	-	-	-	-	-	1000
#4 - 48	1	-	-	04542SF	14542SF	-	-	1000
	1.5	-	-	04543SF	14543SF	-	-	1000
	2	-	-	-	-	-	-	1000
#5 - 40	1	-	-	03552SF	13552SF	-	-	1000
	1.5	-	-	03553SF	13553SF	-	-	1000
	2	-	-	03554SF	13554SF	-	-	1000
#6 - 40	1	-	-	04562SF	14562SF	-	-	1000
	1.5	-	-	04563SF	14563SF	-	-	1000
#6 - 32	1	TL03562SF	TL13562SF	03562SF	13562SF	-	-	1000

Recoil® Strip Feed Part Numbers - Tanged and Tangless®

Unified

Thread Size	Tangless			Magazined on Reels Dia 290mm				
	Nominal Length (in Dia)	Strip Feed Part Number Free Running	Strip Feed Part Number Locking	Strip Feed Part Number Free Running	Strip Feed Part Number Locking	Tanged Strip Feed Part Number MS Free Running	Strip Feed Part Number MS Locking	No. of Inserts
#2 - 56	2.5	TL03525SF	TL13525SF	03525SF	13525SF	-	-	-
	3	TL03526SF	TL13526SF	03526SF	13526SF	-	-	-
#3 - 56	2.5	-	-	04535SF	14535SF	-	-	1000
	3	-	-	04536SF	14536SF	-	-	1000
#4 - 40	2	TL03544SF	TL13544SF	03544SF	13544SF	-	-	-
	2.5	TL03545SF	TL13545SF	03545SF	13545SF	-	-	-
	3	TL03546SF	TL13546SF	03546SF	13546SF	-	-	-
#4 - 48	2	-	-	04544SF	14544SF	-	-	1000
	2.5	-	-	04545SF	14545SF	-	-	1000
	3	-	-	04546SF	14546SF	-	-	1000
#6 - 40	2	-	-	04564SF	14564SF	-	-	1000
	2.5	-	-	04565SF	14565SF	-	-	1000
	3	-	-	04566SF	14566SF	-	-	1000
#6 - 32	1.5	TL03563SF	TL13563SF	03563SF	13563SF	-	-	1000
	2	TL03564SF	TL13564SF	03564SF	13564SF	-	-	1000
	2.5	-	-	03565SF	13565SF	-	-	1000
	3	-	-	03566SF	13566SF	-	-	1000
#8 - 32	1	TL03582SF	TL13582SF	03582SF	13582SF	-	-	1000
	1.5	TL03583SF	TL13583SF	03583SF	13583SF	-	-	1000
	2	TL03584SF	TL13584SF	03584SF	13584SF	-	-	1000
	2.5	-	-	03585SF	13585SF	-	-	1000
	3	-	-	03586SF	13586SF	-	-	1000
#8 - 36	1	-	-	04582SF	14582SF	-	-	1000
	1.5	-	-	04583SF	14583SF	-	-	1000
	2	-	-	04584SF	14584SF	-	-	500
	2.5	-	-	04585SF	14585SF	-	-	500
	3	-	-	04586SF	14586SF	-	-	500
#10 - 24	1	TL03602SF	13602SF	03602SF	13602SF	-	-	1000
	1.5	TL03603SF	13603SF	03603SF	13603SF	-	-	500
	2	TL03604SF	13604SF	03604SF	13604SF	-	-	500
	2.5	-	-	03605SF	13605SF	-	-	500
	3	-	-	03606SF	13606SF	-	-	500
#10 - 32	1	TL04602SF	TL14602SF	04602SF	14602SF	-	-	1000
	1.5	TL04603SF	TL14603SF	04603SF	14603SF	-	-	500
	2	TL04604SF	TL14604SF	04604SF	14604SF	-	-	500
	2.5	-	-	04605SF	14605SF	-	-	500
	3	-	-	04606SF	14606SF	-	-	500



Recoil® Strip Feed Part Numbers - Tanged and Tangless®

Unified

Thread Size	Tangless			Magazined on Reels Dia 290mm				
	Nominal Length (in Dia)	Strip Feed Part Number Free Running	Strip Feed Part Number Locking	Strip Feed Part Number Free Running	Strip Feed Part Number Locking	Tanged Strip Feed Part Number MS Free Running	Strip Feed Part Number MS Locking	No. of Inserts
#12 - 24	1	-	-	03622SF	13602SF	-	-	1000
	1.5	-	-	03623SF	13603SF	-	-	500
	2	-	-	03624SF	13604SF	-	-	500
	2.5	-	-	03625SF	13605SF	-	-	500
	3	-	-	03626SF	13606SF	-	-	500
1/4 - 20	1	TL03042SF	TL13042SF	03042SF	13042SF	-	-	500
	1.5	TL03043SF	TL13043SF	03043SF	13043SF	-	-	500
	2	TL03044SF	TL13044SF	03044SF	13044SF	-	-	250
	2.5	-	-	03045SF	13045SF	-	-	250
	3	-	-	03046SF	13046SF	-	-	250
1/4 - 28	1	TL04042SF	TL14042SF	04042SF	14042SF	-	-	500
	1.5	TL04043SF	TL14043SF	04043SF	14043SF	-	-	500
	2	TL04044SF	TL14044SF	04044SF	14044SF	-	-	500
	2.5	-	-	04045SF	14045SF	-	-	250
	3	-	-	04046SF	14046SF	-	-	250
5/16 - 18	1	TL03052SF	TL13052SF	03052SF	13052SF	-	-	250
	1.5	TL03053SF	TL13053SF	03053SF	13053SF	-	-	250
	2	TL03054SF	TL13053SF	03054SF	13054SF	-	-	250
5/16 - 24	1	TL04052SF	TL14052SF	04052SF	14052SF	-	-	250
	1.5	TL04053SF	TL14053SF	04053SF	14053SF	-	-	250
	2	-	-	04054SF	14054SF	-	-	250
3/8 - 16	1	TL03062SF	TL13062SF	03062SF	13062SF	-	-	250
	1.5	TL03063SF	TL13063SF	03063SF	13063SF	-	-	250
	2	TL03064SF	TL13064SF	03064SF	13064SF	-	-	250
3/8 - 24	1	TL04062SF	TL14062SF	04062SF	14062SF	-	-	250
	1.5	TL04063SF	TL14063SF	04063SF	14063SF	-	-	250
	2	TL04064SF	TL14064SF	04064SF	14064SF	-	-	250
7/16-14	1	-	-	03072SF	13072SF	-	-	125
	1.5	-	-	03073SF	13073SF	-	-	125
	2	-	-	03074SF	13074SF	-	-	125

Recoil® Tapped Hole and Fitted Size Data - BSW

BSW Threads

Thread Nominal	Nominal Length (in Dia.)	Recoil Spec - Free Running			Drill Size		A		B	C		C		E	Basic Length of Insert Nominal Diameter of Screw "D"			
		Part Number	Number of Coils	Free Coil Dia Min./Max.			Minor Diameter		Major Diameter	Class 2B		Class 3B			Inserts Fitted	Q	R	S
					mm	inch	Min	Max	Min	Min	Max	Min	Max					
3/16-24	1	02032	3.00	6.00-6.30	5.00	13/64	0.196	0.202	0.2365	0.2141*	0.2166*	NOT RECOMMENDED	NOT RECOMMENDED	0.1341	0.187	0.146	0.375	0.332
	1.5	02033	4.90												0.281	0.24	0.468	0.426
	2	02034	7.00												0.375	0.334	0.562	0.52
	2.5	02035	9.30												0.468	0.427	0.656	0.612
	3	02036	11.40												0.562	0.521	0.750	0.708
1/4-20	1	02042	3.375	8.10-8.35	6.70	17/64	0.261	0.267	0.3087	0.2820*	0.2849*	NOT RECOMMENDED	NOT RECOMMENDED	0.1860	0.250	0.200	0.475	0.425
	1.5	02043	5.750												0.375	0.325	0.600	0.550
	2	02044	8.000												0.500	0.450	0.725	0.675
	2.5	02045	10.375												0.625	0.575	0.850	0.800
	3	02046	12.750												0.750	0.700	0.975	0.925
5/16-18	1	02052	4.00	9.85-10.05	8.30	21/64	0.328	0.334	0.3777	0.3480*	0.3512*	NOT RECOMMENDED	NOT RECOMMENDED	0.2413	0.312	0.257	0.562	0.507
	1.5	02053	6.60												0.469	0.413	0.719	0.663
	2	02054	9.25												0.625	0.569	0.875	0.819
	2.5	02055	11.85												0.781	0.726	1.031	0.976
	3	02056	14.60												0.937	0.882	1.187	1.132
3/8-16	1	02062	4.375	11.50-11.85	9.90	25/64	0.39	0.398	0.4483	0.4150	0.4185	0.4150*	0.4170*	0.2950	0.375	0.312	0.656	0.594
	1.5	02063	7.250												0.562	0.500	0.844	0.781
	2	02064	10.000												0.750	0.687	1.031	0.969
	2.5	02065	12.875												0.937	0.875	1.219	1.156
	3	02066	15.750												1.125	1.062	1.406	1.344
7/16-14	1	02072	4.500	13.35-14.00	11.50	29/64	0.453	0.463	0.5212	0.4833	0.4871	0.4833*	0.4855*	0.3461	0.437	0.366	0.759	0.687
	1.5	02073	7.375												0.656	0.585	0.978	0.906
	2	02074	10.250												0.875	0.804	1.196	1.125
	2.5	02075	13.125												1.093	1.022	1.415	1.343
	3	02076	16.125												1.312	1.241	1.634	1.562
1/2-12	1	02082	4.25	15.15-15.60	13.00	17/32	0.515	0.525	0.5973	0.5333	0.5575	0.5533*	0.5557*	0.3932	0.500	0.417	0.888	0.792
	1.5	02083	7.05												0.750	0.667	1.125	1.042
	2	02084	9.85												1.000	0.917	1.375	1.292
	2.5	02085	12.45												1.250	1.167	1.625	1.542
	3	02086	15.45												1.500	1.417	1.875	1.792
9/16-12	1	02092	5.125	16.99-17.70	15.00	19/32	0.578	0.588	0.6600	0.6158	0.6201	0.6158*	0.6184*	0.4557	0.562	0.479	0.937	0.854
	1.5	02093	8.250												0.844	0.76	1.219	1.135
	2	02094	11.500												1.125	1.042	1.500	1.417
	2.5	02095	14.750												1.406	1.323	1.781	1.698
	3	02096	17.125												1.687	1.604	2.062	1.979

Recoil® Tapped Hole and Fitted Size Data - BSF

BSF Threads

Thread Nominal	Nominal Length (in Dia.)	Recoil		Spec-Free Running Free Coil Dia Min./Max.	Drill Size		A		B	C		C		E Inserts Fitted	Basic Length of Insert Nominal Diameter of Screw "D"			
		Part Number	Number of Coils		mm	inch	Minor Diameter		Major Diameter	Class 2B		Class 3B			Q	R	S	T
							Min	Max		Min	Max	Min	Max					
3/16-32	1	00032	4.40	5.80-6.00	5.00	13/64	0.192	0.198	0.2247	.2075*	.2098*	NOT RECOMMENDED	NOT RECOMMENDED	0.1475	0.187	0.156	0.327	0.296
	1.5	00033	7.25												0.281	0.250	0.421	0.390
	2	00034	10.15												0.375	0.344	0.515	0.484
	2.5	00035	13.05												0.468	0.437	0.608	0.577
	3	00036	15.95												0.562	0.531	0.702	0.671
1/4-26	1	00042	4.85	7.65-7.90	6.60	17/64	0.257	0.264	0.2957	.2747*	.2774*	NOT RECOMMENDED	NOT RECOMMENDED	0.2008	0.250	0.212	0.423	0.385
	1.5	00043	7.95												0.375	0.337	0.548	0.510
	2	00044	11.15												0.500	0.462	0.673	0.635
	2.5	00045	14.25												0.625	0.587	0.798	0.760
	3	00046	17.45												0.750	0.712	0.923	0.885
5/16-22	1	00052	5.15	9.65-9.90	8.20	21/64	0.323	0.33	0.3662	.3416*	.3447*	NOT RECOMMENDED	NOT RECOMMENDED	0.2543	0.312	0.267	0.516	0.471
	1.5	00053	8.55												0.469	0.424	0.673	0.628
	2	00054	11.85												0.625	0.580	0.829	0.784
	2.5	00055	15.15												0.781	0.736	0.985	0.940
	3	00056	18.55												0.937	0.982	1.141	1.096
3/8-20	1	00062	5.75	11.20-11.50	9.80	25/64	0.385	0.392	0.434	.4070*	.4104*	NOT RECOMMENDED	NOT RECOMMENDED	0.311	0.375	0.325	0.600	0.550
	1.5	00063	9.45												0.562	0.512	0.787	0.737
	2	00064	13.05												0.750	0.700	0.975	0.925
	2.5	00065	16.75												0.937	0.887	1.162	1.112
	3	00066	20.35												1.125	1.075	1.350	1.300
7/16-18	1	00072	6.15	13.00-13.35	11.50	29/64	0.45	0.458	0.503	0.473	0.4767	.4730*	.4751*	0.3663	0.437	0.381	0.687	0.631
	1.5	00073	9.95												0.656	0.600	0.906	0.850
	2	00074	13.75												0.875	0.819	1.125	1.069
	2.5	00075	17.65												1.093	1.037	1.343	1.287
	3	00076	21.45												1.312	1.256	1.562	1.506
1/2-16	1	00082	6.25	14.85-15.25	13.00	33/64	0.513	0.522	0.5736	0.54	0.544	.5400*	.5423*	0.42	0.500	0.737	0.781	0.719
	1.5	00083	10.15												0.750	0.688	1.031	0.969
	2	00084	14.05												1.000	0.938	1.281	1.219
	2.5	00085	17.95												1.250	1.180	1.531	1.469
	3	00086	21.75												1.500	1.438	1.781	1.719

Standard size drills are suggested even though in these sizes they vary slightly from minor diameter limits. Drill sizes are recommended only and test should be carried out to select the one suitable for the material involved.

Countersinking: It is recommended that a 120° countersink is provided before tapping to prevent a feather edge at the start of the lead thread. When design prevents the use of a countersink, any feather edges or deformed material at the thread lead should be removed before tapping. This will facilitate insert installation and reduce the effects of removing the countersinking operation.

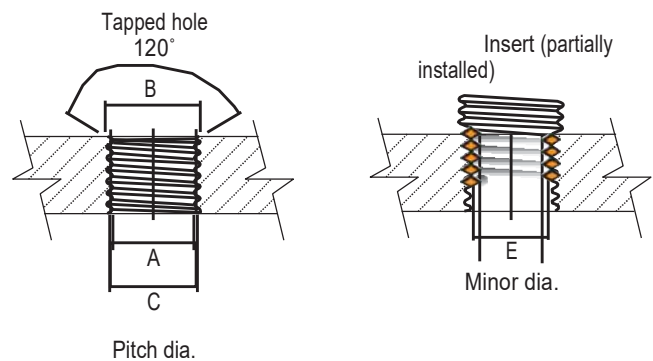

Recoil® Tapped Hole and Fitted Size Data - BSF

BSF Threads

Thread Nominal	Nominal Length (in Dia.)	Recoil Spec-FreeRunning		Free Coil Dia Min./Max.	Drill Size		A		B	C		C		E	Basic Length of Insert Nominal Diameter of Screw "D"			
		Part Number	Number of Coils		mm	inch	Minor Diameter		Major Diameter	Class 2B		Class 3B		Inserts Fitted	Q	R	S	T
							Min	Max		Min	Max	Min	Max					
9/16-16	1	00092	7.25	16.50 -16.85	14.50	37/64	0.577	0.586	0.6362	0.6025	0.6067	0.6025*	0.6049*	0.4825	0.562	0.500	0.843	0.781
	1.5	00093	11.65												0.844	0.782	1.125	1.063
	2	00094	15.95												1.125	1.062	1.406	1.344
	2.5	00095	20.35												1.406	1.344	1.687	1.625
	3	00096	24.75												1.687	1.625	1.968	1.906
5/8-14	1	00102	7.05	18.40 -18.75	16.20	41/64	0.64	0.649	0.7091	0.6708	0.6752	0.6708	.6734*	0.5336	0.625	0.554	0.946	0.875
	1.5	00103	11.25												0.937	0.866	1.258	1.187
	2	00104	15.45												1.250	1.179	1.571	1.500
	2.5	00105	19.75												1.562	1.491	1.883	1.812
	3	00106	23.95												1.875	1.804	2.196	2.125
3/4-12	1	00122	7.25	22.30 -22.70	19.50	49/64	0.765	0.775	0.8478	0.8033	0.8082	0.8033*	0.8062*	0.6432	0.750	0.667	1.125	1.042
	1.5	00123	11.65												1.125	1.042	1.500	1.417
	2	00124	15.95												1.500	1.417	1.875	1.792
	2.5	00125	20.35												1.875	1.792	2.250	2.167
	3	00126	24.75												2.250	2.167	2.625	2.542
7/8-11	1	00142	7.85	25.50 -25.90	22.50	57/64	0.89	0.9	0.9817	0.9332	0.9384	0.9332*	0.9364*	0.7586	0.875	0.784	1.284	1.193
	1.5	00143	12.55												1.312	1.221	1.721	1.630
	2	00144	17.15												1.750	1.659	2.159	2.068
	2.5	00145	21.85												2.187	2.096	2.596	2.505
	3	00146	26.55												2.625	2.534	3.034	2.943
1-10	1	00162	8.25	29.35 -29.80	26.00	11/32	1.031	1.044	1.1173	1.0641	1.0697	1.0641*	1.0675*	0.872	1.000	0.900	1.450	1.350
	1.5	00163	13.05												1.500	1.400	1.950	1.850
	2	00164	17.95												2.000	1.900	2.450	2.350
	2.5	00165	22.75												2.500	2.400	2.950	2.850
	3	00166	27.65												3.000	2.900	3.450	3.350
1-1/4-9	1	00202	9.45	35.90 -36.35	32.50	1 9/32	1.281	1.295	1.3803	1.3212	1.3274	1.3212*	1.3250*	1.1078	1.250	1.139	1.750	1.639
	1.5	00203	14.85												1.875	1.764	2.375	2.264
	2	00204	20.35												2.500	2.389	3.000	2.889
	2.5	00205	25.75												3.125	3.014	3.625	3.514
	3	00206	31.25												3.750	3.639	4.250	4.139



Recoil® Tapped Hole and Fitted Size Data - BSP

BSP Threads

Thread Nominal	Nominal Length (inDia.)	Recoil Spec - Free Running		Free Coil Dia Min. / Max.	Drill Size		A		B	C		C		E	Basic Length of Insert Nominal Diameter of Screw "D"			
		Part Number	Number of Coils		mm	inch	Minor Diameter		Major Diameter	Class 2B		Class 3B		Inserts	Q	R	S	T
							Min	Max	Min	Min	Max	Min	Max	Fitted				
1/8 - 28	1	01022	3.10	11.0 - 11.35	9.900	3/8	0.3900	0.4000	0.4258	0.4058	0.409	NOT RECOMMENDED	NOT RECOMMENDED	0.3372	0.125	0.089	0.287	0.251
	1.5	01023	4.75												0.187	0.151	0.349	0.313
	2	01024	6.35												0.250	0.214	0.412	0.376
	2.5	01025	7.95												0.312	0.276	0.474	0.438
	3	01026	9.60												0.375	0.339	0.537	0.501
1/4 - 19	1	01042	3.05	15.0 - 15.35	13.500	33/64	0.5300	0.5400	0.5803	0.5517	0.5556	NOT RECOMMENDED	NOT RECOMMENDED	0.4506	0.250	0.197	0.488	0.435
	1.5	01043	5.35												0.375	0.322	0.613	0.560
	2	01044	7.35												0.500	0.447	0.738	0.685
	2.5	01045	9.85												0.625	0.572	0.863	0.810
	3	01046	12.15												0.750	0.697	0.988	0.935
3/8 - 19	1	01062	5.85	18.6 - 18.85	17.000	21/32	0.6700	0.6800	0.7184	0.6897	1.6937	NOT RECOMMENDED	NOT RECOMMENDED	0.5886	0.375	0.322	0.613	0.560
	1.5	01063	9.35												0.562	0.509	0.800	0.747
	2	01064	12.95												0.750	0.697	0.988	0.935
	2.5	01065	15.75												0.937	0.884	1.175	1.122
	3	01066	19.25												1.125	1.072	1.363	1.310
1/2 - 14	1	01082	5.25	23.6 - 24.0	21.500	13/16	0.8400	0.8500	0.9092	0.8708	0.8754	NOT RECOMMENDED	NOT RECOMMENDED	0.7336	0.500	0.429	0.820	0.749
	1.5	01083	8.60												0.750	0.679	1.070	0.999
	2	01084	11.95												1.000	0.929	1.320	1.249
	2.5	01085	15.25												1.250	1.179	1.570	1.499
	3	01086	18.60												1.500	1.429	1.820	1.749
5/8 - 14	1	01102	6.95	25.4 - 26	23.500	59/64	0.9150	0.9270	0.9863	0.9478	0.9524	0.9478	0.9506	0.8106	0.625	0.554	0.945	0.874
	1.5	01103	11.25												0.937	0.866	1.257	1.186
	2	01104	15.45												1.250	1.179	1.570	1.499
	2.5	01105	20.35												1.562	1.491	1.882	1.811
	3	01106	23.95												1.875	1.804	2.195	2.124
3/4 - 14	1	01122	8.65	29.3 - 29.8	27.000	1 1/64	1.0530	1.0660	1.1255	1.0868	1.0918	1.0868	1.0898	0.9496	0.750	0.679	1.070	0.999
	1.5	01123	13.75												1.125	1.054	1.445	1.374
	2	01124	18.85												1.500	1.429	1.820	1.749
	2.5	01125	24.05												1.875	1.804	2.195	2.124
	3	01126	29.10												2.250	2.179	2.570	2.499
1" - 11	1	01162	9.15	36.85 - 37.30	33.500	1 9/32	1.3200	1.3350	1.4158	1.3673	1.3727	1.3673	1.3705	1.1926	1.000	0.909	1.410	1.319
	1.5	01163	14.55												1.500	1.409	1.910	1.819
	2	01164													2.000	1.909	2.410	2.319
	2.5	01165	25.25												2.500	2.409	2.910	2.819
	3	01166	30.55												3.000	2.909	3.410	3.319
1 1/4 - 11	1	01202	11.50	46.60 - 47.10	143/64		1.6650	1.6800	1.7571	1.7083	1.7141	1.7083	1.7118	1.5336	1.250	1.159	1.660	1.569
	1.5	01203	18.00												1.875	1.784	2.285	2.194
	2	01204	24.60												2.500	2.409	2.910	2.819
	2.5	01205													3.125	3.034	3.535	3.440
	3	01206													3.750	3.659	4.160	4.069
1 1/2 - 11	1	01242	18.15	52.70 - 53.25	129/32		1.9060	1.9210	1.9893	1.9403	1.9464	1.9403	1.944	1.7656	1.500	1.409	1.910	1.819
	1.5	01243	27.95												2.250	2.159	2.660	2.569
	2	01244	37.85												3.000	2.909	3.410	3.319
	2.5	01245													3.750	3.659	4.160	4.069
	3	01246													4.500	4.409	4.910	4.819

Recoil® Part Numbers Tapped Hole and Fitted Size Data - 8UN

8UN Threads

Thread Nominal Size	Nominal Length (in Dia.)	Free Running Part Number	Screw Locking Part Number	Number of Coils	Free Coil Dia Min./Max.	Drill Hole Dia		Pitch Diameter		Tap Major Dia	Assembled Insert Pitch Diameter		Basic Length of Insert Nominal Diameter of Screw "D"			
						Min	Max	Min	Max		Max	Min	Max	Q	R	S
11/8-8	1	06182	16182	6.95	32.00 - 33.07	1.1300	1.1550	1.1688	1.1757	1.2610	1.0438	1.0528	28.575	25.400	42.863	39.688
	1.5	06183	16183	11.25									42.863	39.688	57.150	53.975
	2	06184	16184	13.45									57.150	53.975	71.438	68.263
	2.5	06185	16185	19.75									71.438	68.263	85.725	82.550
	3	06186	16186	23.95									85.725	82.550	100.013	96.838
11/4-8	1	06202	16202	7.85	35.33 - 36.34	1.2550	1.2800	1.2938	1.3008	1.3860	1.1688	1.1780	31.750	28.575	46.038	42.863
	1.5	06203	16203	12.75									47.625	44.450	61.913	58.738
	2	06204	16204	17.35									63.500	60.325	77.788	74.613
	2.5	06205	16205	22.15									79.375	76.200	93.663	90.488
	3	06206	16206	26.85									95.250	92.075	109.538	106.363
13/8-8	1	06222	16222	8.85	38.50 - 39.75	1.3800	1.4050	1.4188	1.4259	1.5110	1.2938	1.3031	34.925	31.750	49.213	46.038
	1.5	06223	16223	14.15									52.388	49.213	66.675	63.500
	2	06224	16224	19.35									69.850	66.675	84.138	80.963
	2.5	06225	16225	24.65									87.313	84.138	101.600	98.425
	3	06226	16226	29.95									104.775	101.600	119.063	115.888
11/2-8	1	06242	16242	9.85	41.60 - 43.02	1.5050	1.5300	1.5438	1.5510	1.6360	1.4188	1.4283	38.100	34.925	52.388	49.213
	1.5	06243	16243	15.45									57.150	53.975	71.438	68.263
	2	06244	16244	21.25									76.200	73.025	90.488	87.313
	2.5	06245	16245	26.95									95.250	92.075	109.538	106.363
	3	06246	16246	32.65									114.300	111.125	128.588	125.413
15/8-8	1	06262	16262	10.95	47.00 - 48.36	1.6300	1.6550	1.6688	1.6762	1.7610	1.5438	1.5535	41.275	38.100	55.563	52.388
	1.5	06263	16263	17.15									61.913	58.738	76.200	73.025
	2	06264	16264	23.35									82.550	79.375	96.838	93.663
	2.5	06265	16265	29.55									103.188	100.013	117.475	114.300
	3	06266	16266	35.75									123.825	120.650	138.113	134.938
13/4-8	1	06282	16282	11.85	50.30 - 52.30	1.7550	1.7800	1.7938	1.8013	1.8860	1.6688	1.6860	44.450	41.275	58.738	55.563
	1.5	06283	16283	18.55									66.675	63.500	80.963	77.788
	2	06284	16284	25.25									88.900	85.725	103.188	100.013
	2.5	06285	16285	31.85									111.125	107.950	125.413	122.238
	3	06286	16286	38.55									133.350	130.175	147.638	144.463
17/8-8	1	06302	16302	12.85	53.00 - 54.94	1.8800	1.9050	1.9188	1.9264	2.0110	1.7938	1.8038	47.625	44.450	61.913	58.738
	1.5	06303	16303	19.95									71.438	68.263	85.725	82.550
	2	06304	16304	27.15									95.250	92.075	109.538	106.363
	2.5	06305	16305	34.25									119.063	115.888	133.350	130.175
	3	06306	16306	41.45									142.875	139.700	157.163	153.988
2 - 8	1	06322	16322	13.75	56.87 - 57.75	2.0300	2.0438	2.0515	2.1360	1.9188	1.9289	2.0050	50.800	47.630	65.090	61.910
	1.5	06323	16323	21.45									76.200	73.030	90.490	87.310
	2	06324	16324	27.95									101.600	98.430	115.890	112.710
	2.5	06325	16325	36.65									127.000	123.830	141.290	138.110
	3	06326	16326	44.25									152.400	149.230	166.690	163.510

Design and Installation Data - NPT and ANPT

Drilled Hole

Nominal Thread Size	S Diameter		Min Depth	
	Reaming (ANPT)	No Reaming (NPT)	Plug Tap S_P	Bottom Tap S_B
	1	2	3	4
1/8-27	U (.3680)	W (.3860)	0.592	0.466
1/4-18	31/64 (.4844)	33/64 (.5156)	0.833	0.606
3/8-18	5/8 (.6250)	21/32 (.6562)	0.840	0.619
1/2-14	25/32 (.7812)	13/16 (.8125)	1.069	0.775
3/4 - 14	63/64 (.9844)	1-1/64 (1.0156)	1.074	0.794
1-11-1/2	1-1/4 (1.2500)	1-9/32 (1.2812)	1.302	0.972

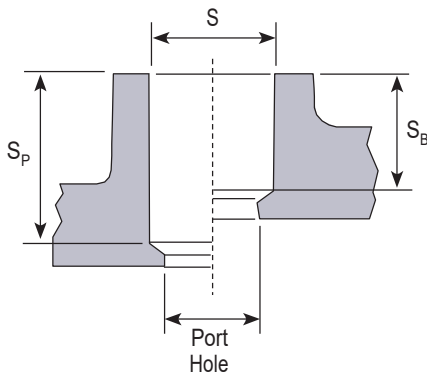

Reamed Hole

M Diameter		Min Depth*	
Min	Max	Plug Top R_P	Bottom Top R_B
5	6	7	8
0.3963	0.4047	0.519	0.447
0.5265	0.5386	0.676	0.578
0.6619	0.6740	0.684	0.590
0.8247	0.8247	0.841	0.726
1.0351	1.0494	0.846	0.745
1.2958	1.3125	1.005	0.892

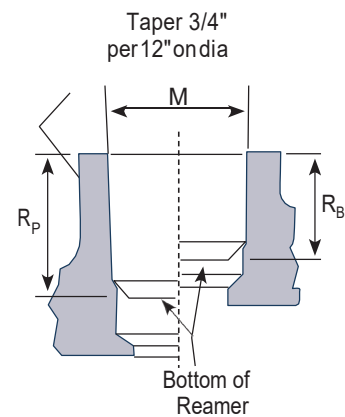

Tool Part Numbers

Nominal Thread Size	Tap*			Gauges		Inserting Tool	Extracting Tool
	Plug	Bottom	Plain Taper Plug	L ₁ Thread Plug	L ₃ Thread Plug		
				25	26		
1/8-27	46025	46026	66023P	66023L1	66023L3	50313	50003
1/4-18	46045	46046	66043P	66043L1	66043L3	50438	50003
3/8-18	46065	46066	66063P	66063L1	66063L3	50500	50003
1/2-14	46085	46086	66083P	66083L1	66083L3	50688	50003
3/4-14	46125	46126	66126P	66123L1	66123L3	50875	50004
1-11-1/2	46165	46166	66166P	66123L1	66163L3	51125	50004

*May also be used in aluminium, cast iron, mild steel, and brass for limited production. Production taps for these and other materials are available on special order.

Insert Identification

Nominal Thread Size	Part No.	Nominal Length	No. of Coils	
			(Counted from Notch) Max	
1/8-27	06023	0.273	5.15	0.511
1/4-18	06043	0.394	4.95	0.680
3/8-18	06063	0.407	5.35	0.828
1/2-14	06083	0.534	5.45	1.035
3/4-14	06123	0.553	5.8	1.262
1-11-1/2	06163	0.661	5.65	1.575

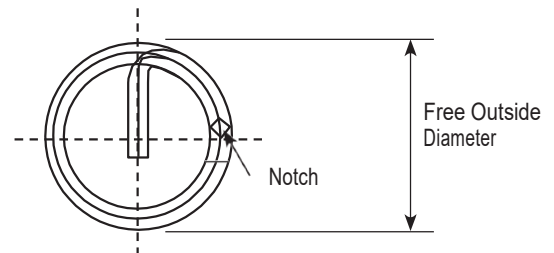

Design and Installation Data - NPT and ANPT

Tapped Hole

Nominal Thread Size	Pitch Diameters			Major Dia. Max (C)	Min Depth Plug Tap (T _P) Bottom Tap (T _B)	
	E ₁₀	E ₁₁	E ₁₃		13	14
1/8-27	0.41761	0.42770	0.41066	0.459	0.536	0.409
1/4-18	0.55967	0.57391	0.54925	0.621	0.749	0.568
3/8-18	0.69429	0.70929	0.68388	0.757	0.756	0.580
1/2-14	0.86579	0.88579	0.85240	0.947	0.962	0.740
3/4-14	1.07504	1.09623	1.06165	1.157	0.966	0.759
1-11-1/2	1.34531	1.37031	1.32901	1.445	1.172	0.929

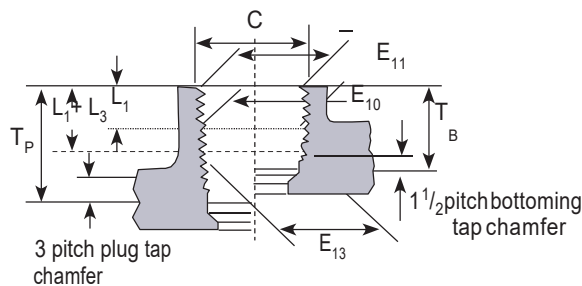

Assembled Insert Specifications

Basic Lengths			Basic Pitch Diameters				
L ₁	L ₂	L ₁ + L ₃	E ₀	E ₁	E ₂	E ₃	D
16	17	18	19	20	21	22	23
0.1615	0.26385	0.27261	0.36351	0.37351	0.38000	0.35656	0.405
0.2278	0.40178	0.39447	0.47739	0.49163	0.50250	0.46697	0.540
0.240	0.40778	0.40667	0.61201	0.62701	0.63750	0.60160	0.675
0.320	0.53371	0.53429	0.75843	0.77843	0.79179	0.74504	0.840
0.399	0.54571	0.55329	0.96768	0.98887	1.00179	0.95429	1.050
0.400	0.68278	0.66087	1.21363	1.238631	1.25630	1.19733	1.315

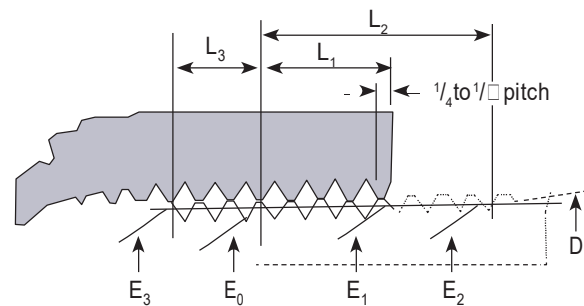

Note:

Depths of reaming and tapping are reference dimensions only. Actual hole depths are governed by use of pipe thread gauges.

D = Outside diameter of pipe – major diameter of pipe thread at L₂ from end of pipe

E₀ = Basic pitch diameter of thread at end of pipe
= D – (0.05D + 1.1) P

E₁ = Basic pitch diameter of thread at end of coupling
= E₀ + 0.0625L₁

E₂ = Basic pitch diameter of thread at L₂ from end of pipe
= E₀ + 0.0625L₂

E₃ = Basic pitch diameter of thread at L₃ from end of pipe
= E₀ – 0.1875P

L₁ = Normal engagement by hand between external and internal threads

L₂ = Effective length of external thread
= P(0.8D + 6.8)

L₃ = Normal wrench take-up

L₁ + L₃ = Effective length of internal threads.
Nominal insert length.

Minimum full thread in blind holes. Minimum boss thickness for through holes.

Important Note:

Spiral Leakage could occur due to extremes of truncation and pitch diameter tolerances can create crest and root (major and minor diameter) clearances that might allow a void. The normal practice of using sealing compounds should be followed when producing Recoil® Pipe Thread Insert assemblies.

Process Sheet - NPT and ANPT

Operation	ANPT NPT	Procedure
Drilling	Col. 1 Col. 2	Normal drilling methods should be followed. Drill sizes are recommended only and test should be carried out to select the one suitable for the material and process involved. Drill to depth given in col. 3 or 4.
Taper reaming		Check hole with plain taper plug gauge (part numbers shown in Col. 27). Ream to depth shown in Col. 7 or 8 and diameter as shown in Col. 5 and 6.
Tapping	Col. 25 or 26	Normal tapping methods should be followed. Recoil pipe thread taps are wrapped with a strand of copper wire to indicate approximate tapping depth. Actual depth and size must be controlled by gauging. Tap to given depth in Col. 14 or 15.
Gauging	Col. 27	Plain taper plug: Used to check taper, roundness, and diameter at the crest of thread.
	Col. 28	L ₁ thread plug: used to check diameter, lead, form, and taper of that portion of thread which will be engaged when the male thread part is screwed in by hand. This is the only gauge used when working to NPT. Tapped hole must be within MIN and MAX steps on L ₁ gauge.
	Col. 29	L ₃ thread plug: Used to check diameter, lead, form, and taper of thread at lower portion of hole – those threads that will be engaged by wrench pressure.
		<p>ANPT GAUGING PROCEDURE</p> <p>ANPT gauging requires the use of L₁, L₃ and plain taper gauges. L₁ and L₃ gauges have notches denoting Maximum (MX), Basic (B), and Minimum (MN). The plain taper plug gauge has three additional notches which indicate truncation tolerances: Maximum Tolerance (MXt), Basic Tolerances (Bt), and Minimum Tolerance (MNt). The use of these three gauges establishes an acceptable threaded hole as Maximum, Basic or Minimum.</p> <p>First, gauge the hole with the L₁ gauge, noting the actual position of the steps in relation to the hole. If the Minimum step reaches the edge of the hole, the hole is classified Minimum. If L₁ stops at Basic or Maximum, the hole is classified either Basic or Maximum.</p> <p>Now gauge the hole with the L₃ gauge, checking that the proper step comes into the same relative position with the edge of the hole that the L₁ did. The L₃ gauge must not vary more than ½ turn from the position established by the L₁ gauge.</p> <p>Finally, check the hole with the plain taper gauge. The edge of the hole must come between the Minimum (MN) and Minimum Tolerance (MNt) steps if Minimum is what the L₁ gauge showed the hole to be. (If the L₁ gauge showed the hole to be Basic, the plain plug would have to be between B and Bt; if L₁ were Maximum, the plain plug would have to be between MX and MXt).</p> <p>Gauging of the assembled insert is not necessary if this procedure has been followed.</p>
Inserts	Page 64	The same Recoil® inserts are used for both ANPT and NPT.
Installation	Col. 30	Wind the insert in with light pressure until 1/4 to 1/2 below the surface, driving tang towards the bottom of the hole.

Process Sheet - NPT and ANPT

Operation	ANPT NPT	Procedure												
Tang Removal	Col. 1 Col. 2	Remove tool and sit back on top of tang. Tap down sharply. Do not twist tang off. Or with long nosed pliers pull the tang out.												
Assembly		<p>We recommend that a suitable non hardening paste type sealing compound be used with ANPT and NPT pipe threads. Application factors such as machining accuracy, type of fluid gas flowing through the connection, pressures, temperature and pipe material will determine the type of sealant best suited for the individual application. The following typical compounds are suggested for the conditions listed:</p> <table> <tr> <td>Petroleum oils</td> <td>Antiseize compound per MIL-A-907</td> </tr> <tr> <td>Water, Steam</td> <td>(Led-Plate 250, product of Armitage Laboratories)</td> </tr> <tr> <td>Oxygen system</td> <td>Thread compound per MIL-T-5542 (Rectorseal-15, product of Rector Well Equipment Company)</td> </tr> </table>	Petroleum oils	Antiseize compound per MIL-A-907	Water, Steam	(Led-Plate 250, product of Armitage Laboratories)	Oxygen system	Thread compound per MIL-T-5542 (Rectorseal-15, product of Rector Well Equipment Company)						
Petroleum oils	Antiseize compound per MIL-A-907													
Water, Steam	(Led-Plate 250, product of Armitage Laboratories)													
Oxygen system	Thread compound per MIL-T-5542 (Rectorseal-15, product of Rector Well Equipment Company)													
Torque		<p>After applying thread compound to male thread, assemble male thread into installed insert using the following tightening torques per MIL-T-542.</p> <table> <tr> <td>1/8-27</td> <td>150 Inch pounds</td> </tr> <tr> <td>1/4-18</td> <td>250 Inch pounds</td> </tr> <tr> <td>3/8-18</td> <td>450 Inch pounds</td> </tr> <tr> <td>1/2-14</td> <td>600 Inch pounds</td> </tr> <tr> <td>3/4-14</td> <td>950 Inch pounds</td> </tr> <tr> <td>1-11-1/2</td> <td>1800 Inch pounds</td> </tr> </table>	1/8-27	150 Inch pounds	1/4-18	250 Inch pounds	3/8-18	450 Inch pounds	1/2-14	600 Inch pounds	3/4-14	950 Inch pounds	1-11-1/2	1800 Inch pounds
1/8-27	150 Inch pounds													
1/4-18	250 Inch pounds													
3/8-18	450 Inch pounds													
1/2-14	600 Inch pounds													
3/4-14	950 Inch pounds													
1-11-1/2	1800 Inch pounds													



Recoil® Tapped Hole and Fitted Size Data - BA

BA Threads

Thread Nominal	Nominal Length (in Dia.)	RecoilSpec-FreeRunning		Free Coil Dia. Min. / Max.	Drill Size		A		B	C		C		E	Basic Length of Insert Nominal Diameter of Screw "D"			
		Part Number	Number of Coils		mm	inch	Minor Diameter		Major Diameter	Class 2B		Class 3B		Inserts	Q	R	S	T
							Min	Max		Min	Max	Min	Max					
0	1	00502	4.15	7.40-7.50	6.20	-	0.2410	0.2460	0.2805	0.2598	0.2645	-	-	0.1890	0.236	0.197	0.413	0.374
	1.5	00503	7.00												0.354	0.315	0.531	0.492
	2	00504	9.85												0.472	0.433	0.649	0.610
	2.5	00505	12.80												0.591	0.552	0.768	0.729
	3	00506													0.709	0.670	0.886	0.847
2	1	00522	4.25	5.70-5.85	4.90	-	0.1910	0.1960	0.2208	0.2042	0.2079	-	-	0.1468	0.185	0.153	0.329	0.297
	1.5	00523	7.05												0.278	0.246	0.422	0.390
	2	00524	9.85												0.370	0.338	0.514	0.482
	2.5	00525	12.75												0.463	0.431	0.607	0.575
	3	00526	15.55												0.555	0.523	0.699	0.667
4	1	00542	3.85	4.40-4.55	3.80	-	0.1470	0.1520	0.1711	0.1574	0.1605	-	-	0.1106	0.142	0.116	0.259	0.233
	1.5	00543	6.45												0.213	0.187	0.330	0.304
	2	00544	9.05												0.283	0.257	0.400	0.374
	2.5	00545	11.65												0.354	0.328	0.471	0.445
	3	00546	14.35												0.425	0.399	0.542	0.516
6	1	00562	3.45	3.55-3.60	2.90	-	0.1130	0.1160	0.1339	0.1226	0.1252	-	-	0.0850	0.110	0.089	0.204	0.183
	1.5	00563	6.00												0.165	0.144	0.259	0.238
	2	00564	8.50												0.220	0.199	0.314	0.293
	2.5	00565													0.276	0.255	0.370	0.349
	3	00566	13.50												0.331	0.310	0.425	0.404

Recoil® STITaps

Recoil Insert Taps

Recoil taps differ from standard taps dimensionally and only Recoil Screw Thread Insert (STI) Taps are suitable for use with Recoil Wire Thread Inserts. Recoil taps are manufactured to precise standards from either High Speed Steel (HSS) with ground threads and are available with taper, intermediate, and bottoming leads. They have a larger diameter but the same pitch as a standard tap in order to accommodate the wire insert. Spiral point and spiral flute machine taps are also available for volume production purposes. For all sparkplug applications, pilot nose taps are recommended and are available for common metric thread sizes. The Recoil thread insert when installed into a correctly tapped hole will provide the applicable internal thread tolerance for the installed bolt.

Note: Tapped hole size can be significantly affected by variations in drill size, parent material, or lubricant so in close tolerance applications some testing for an optimum combination is recommended.

Metric thread tolerance equivalents standards		
	Standards	Recoil Standards
Medium	Metric 6H	5H
Close	Metric 5H	4H5H

Tap Type and Applications

The most commonly used type of Recoil taps are defined together with their typical applications. The Taper, Intermediate, and Bottoming are short machine taps (suitable for hand tapping), while the Spiral Point and Spiral Flute are used in production applications.

Surface Coatings

Recoil taps can be supplied in different surface coatings for special order requirements. Benefits of surface coatings include:

- Longer tool life
- Increased productivity
- Tools can be run at higher feeds and speeds
- Lower maintenance costs

Unified Thread Class

In the unified thread system, the minimum pitch diameter for a 2B hole (medium fit) or 3B hole (close fit) are the same, while the maximum pitch diameter is greater on the 2B hole (medium fit). Recoil taps for unified threads are made to a 3B hole (close fit) tolerance.

Metric Thread Class

In the metric thread system the minimum pitch diameter for a 5H hole (medium fit) or 4H5H hole (close fit) are the same, while the maximum pitch diameter is greater on the 5H hole (medium fit). Recoil taps for metric threads are made to 4H5H hole (close fit) tolerance.

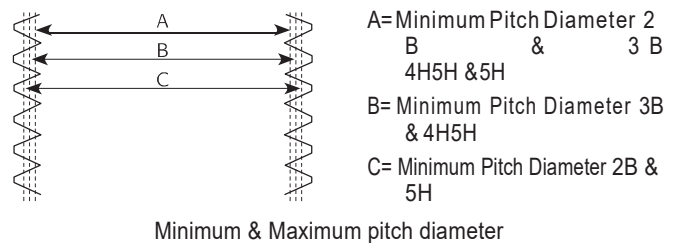

Titanium Carbonitride - TiCNite (TiCN)

TiCNite coated taps have a very high surface hardness and are generally tougher than other coating materials. It has a high resistance to edge chipping.

Titanium Nitride - TiNite (TiN)

TiNite coating is a good choice for protecting the tap. It can achieve a longer life than uncoated taps and can be used at higher speeds.

Chromium Nitride (CrN)

This PVD coating was developed for use in non-ferrous areas where titanium based coatings were not successful. It is recommended for the machining and forming of titanium and copper and is harder than conventional chrome plating. The PVD coating process has no environmental side effects.

Recoil® STITaps

Taper

Taper (or Roughing Taps) are used for starting precision and difficult holes. This tap has a lead of eight threads, but no size reduction.



Intermediate

Intermediate (or Plug/Second), used in most general purpose applications to facilitate thread cutting true to the drilled hole. The tap has a lead of four threads, but no size reduction.



Bottoming

Bottoming Taps are used to ensure the minimum thread run-out when tapping to the bottom of blind holes. The tap has a lead of two threads and would normally be preceded by a taper or an intermediate tap.



Pilot Nose

Pilot nose taps have been developed for repairing damaged threads without the need for drilling prior to tapping. This style of tap allows the use of the existing thread as a guide in tapping a straight hole. This style of tap is widely used in repairing damaged spark plug threads.



Spiral Flute

Spiral Flute taps are recommended for machine tapping for all blind hole applications, particularly in soft materials such as copper, magnesium and aluminium which produce long stringy swarf.



Spiral Point

Spiral Point Taps are recommended for machine tapping through holes. These taps provide for chip clearance within the lead of the tap.



Thredflo 'Roll Thread' Taps

These taps are designed for machine tapping in ductile materials with higher elasticity e.g. materials with a low silicon content, aluminium and some stainless steels. This tap is designed without flutes or cutting faces, but with special roll forming lobes. It has short tapered leads for through or blind holes and is made from HSS.



Recoil® STITaps

Recoil Tap Part Numbering System

The system of identification used for Recoil taps is categorized into two primary sections: Inch threads and Metric threads.

The tap annotation for both thread designations is very similar and therefore easy to follow .

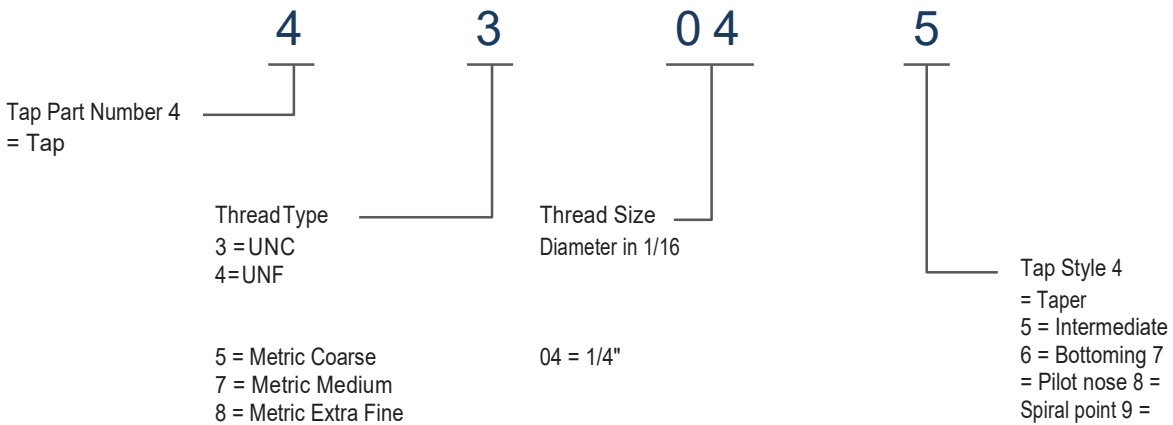

Example-43045=UNC 1/4-20 Intermediate Tap

Screw Pitch Gauge

It is critical that inserts match the tapped hole exactly as some inch and metric are very close but only one is exactly right. A screw pitch gauge is the perfect tool to identify exact TPI or pitch. The bolt diameter should be measured and matched to the closest size

over, relating to the TPI or pitch of the thread. In general, major diameter of bolt or male thread will always be slightly less than the exact diameter listed in the thread identification and drill chart.

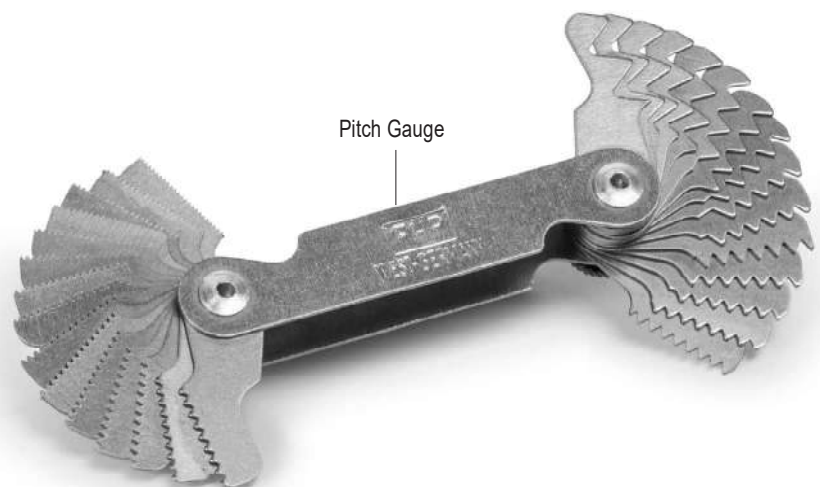

Tap Terminology

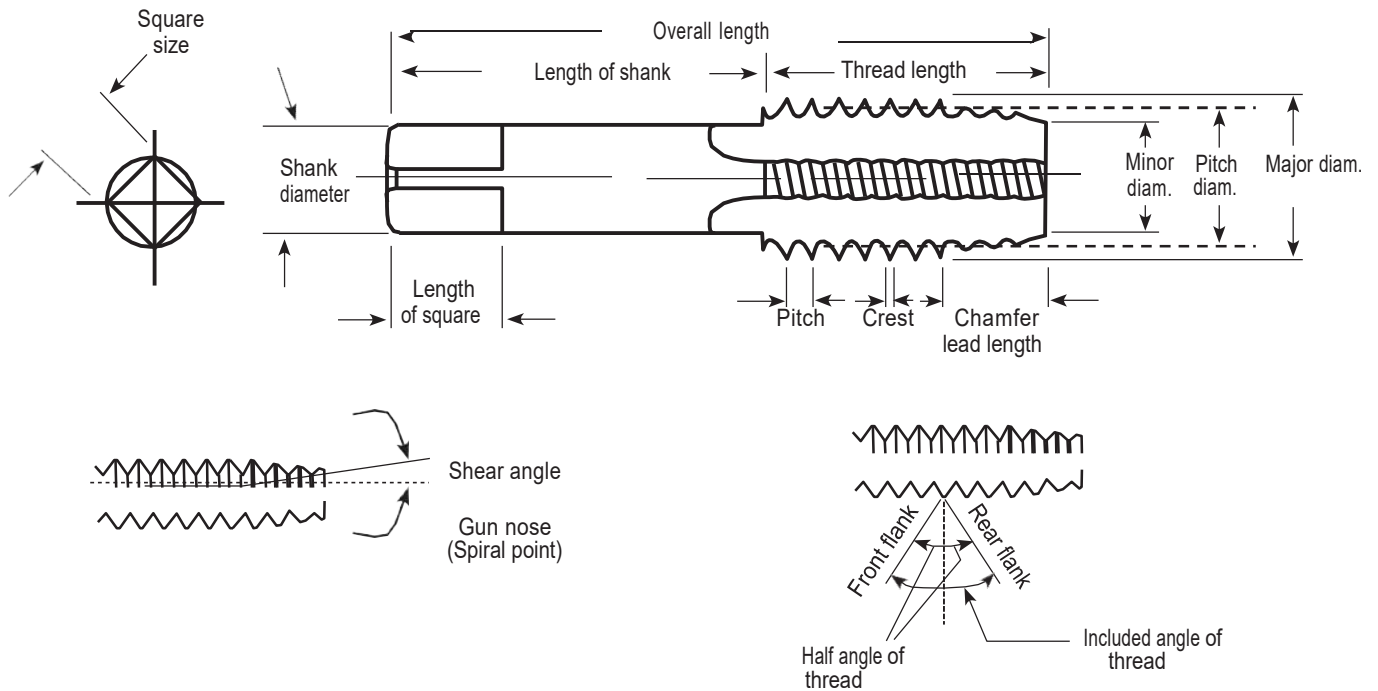

Actual Size

An actual size is a measured size

Allowance

An allowance is the prescribed difference between the design (maximum material) size and the basic size. It is numerically equal to the absolute value of the ISO term fundamental deviation.

Angle of Thread

The included angle between the flanks of a thread measured in an axial plane

Back Taper

A slight taper on the threaded portion of the tap making the pitch diameter near the shank smaller than that at the centre

Basic

The theoretical or nominal standards size from which all variations are made

Chamfer

The tapered and relieved cutting teeth at the front end of the threaded section. Common types of chamfer are taper, intermediate or bottoming

Crest

The top joining the two sides or flanks of a thread

Crest Clearance

The space between the crest of a thread and the root of its component

Cutting Face

The leading face of the land

Flank

The surface of the thread, sometimes referred to as the side of the thread which connects the crest with the root

Flute

The longitudinal channels formed on a tap to create cutting edges on the thread profile

Hand of Threads

- A Right Hand Thread is advanced by turning it to the right or clockwise
- A Left Hand Thread is advanced by turning it to the left or anti clockwise
- All left handed threads are designated LH

Heel

The following side of the land

Height of the Thread

In profile, the distance between the crest and bottom section of the thread measured normal to the axis

Helix Angle - Flute

Flutes of taps are sometimes cut helically instead of straight. This helix angle is the angle made by the flute with the axis of the tap. (Helical Flutes are commonly referred to as spiral flutes.)

Recoil® STI Taps - Part Numbers and Dimensions

Thread Size	Taper	Intermediate	Bottoming	Spiral Point	Spiral Flute	Overall Length	Thread Length	Shank Diameter	Square Drive
Metric Coarse									
M2 - 0.4	45024	45025	45026	45028	45029	45	10	2.80	2.24
M2.2-0.45	45014	45015	45016	45018	45019	48	11	3.15	2.50
M2.5-0.45	45254	45255	45256	45258	45259	48	11	3.15	2.50
M3 - 0.5	45034	45035	45036	45038	45039	50	13	3.55	2.80
M3.5 - 0.6	45354	45355	45356	45358	45359	53	13	4.50	3.55
M4 - 0.7	45044	45045	45046	45048	45049	58	16	5.00	4.00
M5 - 0.8	45054	45055	45056	45058	45059	66	19	6.30	5.00
M6 - 1	45064	45065	45066	45068	45069	72	22	8.00	6.30
M7 - 1	45074	45075	45076	-	-	72	22	9.00	7.10
M8 - 1.25	45084	45085	45086	45088	45089	80	24	10.00	8.00
M9 - 1.25	45094	45095	45096	-	-	85	25	8.00	6.30
M10 - 1.5	45104	45105	45106	45108	45109	89	29	9.00	7.10
M11 - 1.5	45114	45115	45116	-	-	89	29	9.00	7.10
M12-1.75	45124	45125	45126	45128	45129	95	30	11.20	9.00
M14 - 2	45144	45145	45146	-	-	102	32	12.50	10.00
M15 - 2	45154	45155	45156	-	-	112	37	14.00	11.20
M16 - 2	45164	45165	45166	45168	45169	112	37	14.00	11.20
M18 - 2.5	45184	45185	45186	-	-	118	38	16.00	12.50
M20 - 2.5	45204	45205	45206	-	-	130	45	18.00	14.00
M22 - 2.5	45224	45225	45226	-	-	135	48	20.00	16.00
M24 - 3	45244	45245	45246	-	-	135	48	20.00	16.00
M27 - 3	45274	45275	45276	-	-	151	51	22.40	18.00
M30 - 3.5	45304	45305	45306	-	-	162	57	25.00	20.00
M30 - 3	45304-3	45305-3	45306-3	-	-	162	57	25.00	20.00
M33 - 3.5	45334	45335	45336	-	-	170	60	28.00	22.40
M36 - 4	45364	45365	45366	-	-	170	60	28.00	22.40
M39 - 4	45394	45395	45396	-	-	187	67	31.50	25.00
M42 - 4.5	45424	45425	45426	-	-	187	67	31.50	25.00
M42 - 4	45424-4	45425-4	45426-4	-	-	200	70	35.50	28.00
M52 - 5	45524	45525	45526	-	-	221	76	40.00	31.50

Note: The taps listed above represent the most popular of the Recoil taps available. Other sizes and types are available including BSW,BSF, NPT, BA, 8UN etc. Tap dimensions based upon international (ISO) standard. Dimensions are reference only and may be changed without notice.

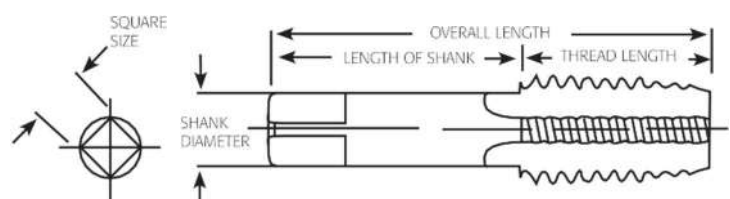

Recoil® STI Taps - Part Numbers and Dimensions

Thread Size	Taper	Intermediate	Bottoming	Spiral Point	Spiral Flute	Overall Length	Thread Length	Shank Diameter	Square Drive
Metric Fine									
M8 - 1	47084	47085	47086	-	-	80	24	10.00	8.00
M9 - 1	47094	47095	47096	-	-	85	25	8.00	6.30
M10-1.25	47104	47105	47106	47108	47109	85	25	8.00	6.30
M10 - 1	48104	48105	48106	48108	48109	85	25	8.00	6.30
M11-1.25	47114	47115	47116	-	-	89	29	9.00	7.10
M11 - 1	48114	48115	48116	-	-	89	29	9.00	7.10
M12 - 1.5	47124	47125	47126	-	-	95	30	11.20	9.00
M12-1.25	48124	48125	48126	-	-	95	30	11.20	9.00
M14 - 1.5	47144	47145	47146	-	-	102	32	12.50	10.00
M14-1.25	48144	48145	48146	-	-	102	32	12.50	10.00
M15 - 1.5	47154	47155	47156	-	-	112	37	14.00	11.20
M16 - 1.5	47164	47165	47166	-	-	112	37	14.00	11.20
M18 - 2	47184	47185	47186	-	-	112	37	14.00	11.20
M18 - 1.5	48184	48185	48186	-	-	112	37	14.00	11.20
M20 - 2	47204	47205	47206	-	-	118	38	16.00	12.50
M20 - 1.5	48204	48205	48206	-	-	118	38	16.00	12.50
M22 - 2	47224	47225	47226	-	-	130	45	18.00	14.00
M22 - 1.5	48224	48225	48226	-	-	130	45	18.00	14.00
M24 - 2	47244	47245	47246	-	-	135	48	20.00	16.00
M24 - 1.5	48244	48245	48246	-	-	135	48	20.00	16.00

Note: The taps listed above represent the most popular of the Recoil taps available. Other sizes and types are available including BSW,BSF, NPT, BA, 8UN etc.

Tap dimensions based upon international (ISO) standard. Dimensions are reference only and may be changed without notice.

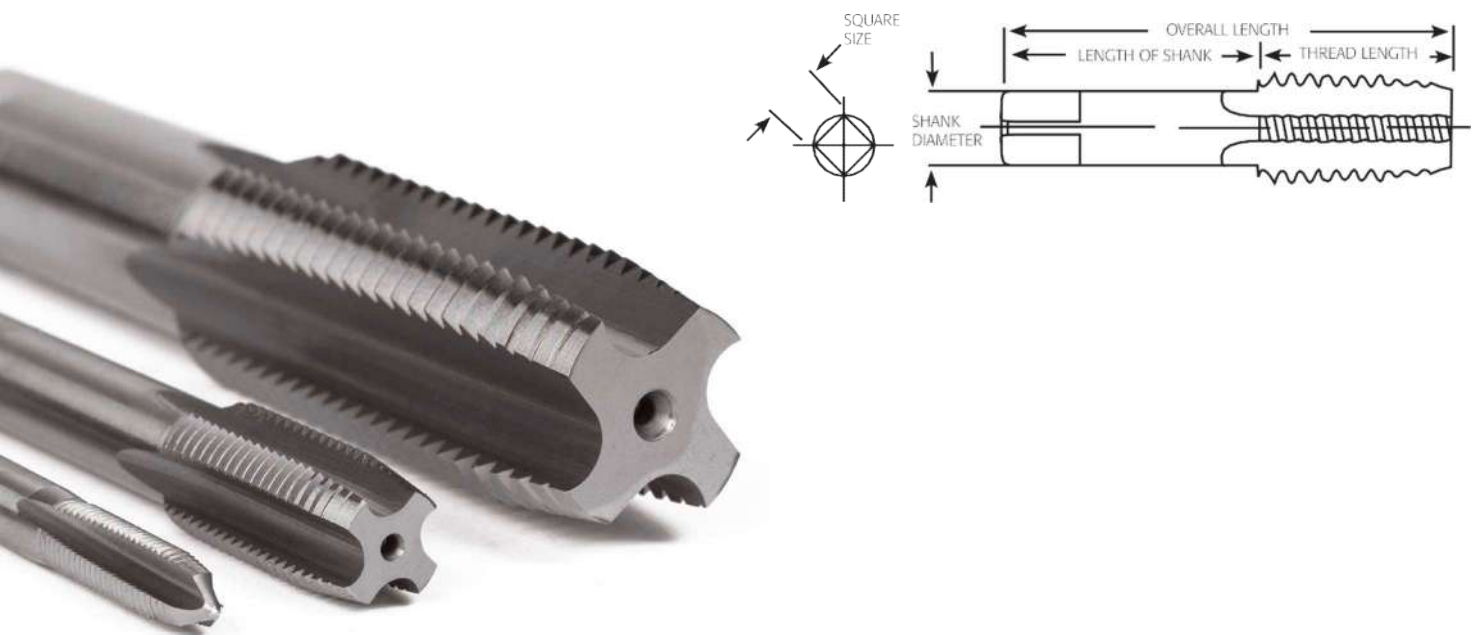

Recoil® STI Taps - Part Numbers and Dimensions

Thread Size	Taper	Intermediate	Bottoming	Spiral Point	Spiral Flute	Overall Length	Thread Length	Shank Diameter	Square Drive
Unified Coarse									
#2 - 56	43524	43525	43526	43528	43529	1.875	0.562	0.141	0.110
#3 - 48	43534	43535	43536	43538	43539	1.937	0.625	0.141	0.110
#4 - 40	43544	43545	43546	43548	43549	2.000	0.687	0.141	0.110
#5 - 40	43554	43555	43556	43558	43559	2.125	0.750	0.168	0.131
#6 - 32	43564	43565	43566	43568	43569	2.375	0.875	0.194	0.152
#8 - 32	43584	43585	43586	43588	43589	2.375	0.937	0.220	0.165
#10 - 24	43604	43605	43606	43608	43609	2.500	1.000	0.255	0.191
#12 - 24	43624	43625	43626	43628	43629	2.718	1.125	0.318	0.238
1/4 - 20	43044	43045	43046	43048	43049	2.718	1.125	0.318	0.238
5/16 - 18	43054	43055	43056	43058	43059	2.937	1.250	0.381	0.286
3/8 - 16	43064	43065	43066	43068	43069	3.375	1.656	0.367	0.275
7/16 - 14	43074	43075	43076	43078	43079	3.593	1.656	0.429	0.322
1/2 - 13	43084	43085	43086	43088	43089	3.812	1.812	0.480	0.360
9/16 - 12	43094	43095	43096	43098	43099	4.031	1.812	0.542	0.406
5/8 - 11	43104	43105	43106	43108	43109	4.250	2.000	0.590	0.442
3/4 - 10	43124	43125	43126	43128	43129	4.687	2.218	0.697	0.523
7/8 - 9	43144	43145	43146	43148	43149	5.125	2.500	0.800	0.600
1 - 8	43164	43165	43166	43168	43169	5.750	2.562	1.021	0.766
1 1/8-7	43184	43185	43186	-	-	-	-	-	-
1 1/4-7	43204	43205	43206	-	-	-	-	-	-
1 3/8-6	43224	43225	43226	-	-	-	-	-	-
1 1/2-6	43244	43245	43246	-	-	-	-	-	-
Unified Fine									
#3 - 56	44534	44535	44536	43538	43589	1.937	0.625	0.141	0.110
#4 - 48	44544	44545	44546	44548	44549	2.000	0.687	0.141	0.110
#6 - 40	44564	44565	44566	44568	44569	2.125	0.750	0.168	0.131
#8 - 36	44584	44585	44586	44588	44589	2.375	0.937	0.220	0.165
#10 - 32	44604	44605	44606	44608	44609	2.500	1.000	0.255	0.191
#12 - 28	44624	44625	44626	-	-	2.718	1.125	0.318	0.238
1/4 - 28	44044	44045	44046	44048	44049	2.718	1.125	0.318	0.238
5/16 - 24	44054	44055	44056	44058	44059	2.937	1.250	0.381	0.286
3/8 - 24	44064	44065	44066	44068	44069	3.156	1.438	0.323	0.242
7/16 - 20	44074	44075	44076	44078	44079	3.375	1.656	0.367	0.275
1/2 - 20	44084	44085	44086	44088	44089	3.593	1.656	0.429	0.322
9/16 - 18	44094	44095	44096	44098	44099	3.812	1.812	0.480	0.360
5/8 - 18	44104	44105	44106	44108	44109	4.031	1.812	0.542	0.406
3/4 - 16	44124	44125	44126	44128	44129	4.468	2.000	0.652	0.489
7/8 - 14	44144	44145	44146	44148	44149	5.125	2.500	0.800	0.600
1 - 12	44164	44165	44166	44168	44169	5.437	2.562	0.896	0.672
1 - 14	44164-14	44165-14	44166-14	44168	44169	5.437	2.562	0.896	0.672
1 1/8 - 12	44184	44185	44186	-	-	-	-	-	-
1 1/4 - 12	44204	44205	44206	-	-	-	-	-	-
1 3/8 - 12	44224	44225	44226	-	-	-	-	-	-
1 1/2 - 12	44244	44245	44246	-	-	-	-	-	-

Note: Tap dimensions are based on American standard (ANSI).

Dimensions are reference only and may be changed without notice.

Dimensions are in inches.

Recoil® STI Taps - Part Numbers and Dimensions

Thread Size	Taper	Intermediate	Bottoming	Spiral Point	Spiral Flute	Overall Length	Thread Length	Shank Diameter	Square Drive
BSW									
1/8 - 40	42024	42025	42026			53.00	13.00	4.00	3.15
3/16 - 24	42034	42035	42036	42038	42039	67.00	19.00	6.30	5.00
1/4 - 20	42044	42045	42046	42048	42049	72.00	22.00	8.00	6.30
5/16 - 18	42054	42055	42056	42058	42059	80.00	24.00	10.00	8.00
3/8 - 16	42064	42065	42066	42068	42069	85.00	25.00	8.00	6.30
7/16 - 14	42074	42075	42076	-	-	95.00	30.00	11.20	9.00
1/2 - 12	42084	42085	42086	-	-	95.00	30.00	11.20	9.00
9/16 - 12	42094	42095	42096	-	-	102.00	32.00	12.50	10.00
5/8 - 11	42104	42105	42106	-	-	112.00	37.00	14.00	11.20
3/4 - 10	42124	42125	42126	-	-	118.00	38.00	16.00	12.50
7/8 - 9	42144	42145	42146	-	-	135.00	48.00	20.00	16.00
1 - 8	42164	42165	42166	-	-	135.00	48.00	20.00	16.00
1 1/8 - 7	42184	42185	42186	-	-	151.00	51.00	22.40	18.00
1 1/4 - 7	42204	42205	42206	-	-	162.00	57.00	25.00	20.00
1 3/8 - 6	42224	42225	42226	-	-	170.00	60.00	28.00	22.40
1 1/2 - 6	42244	42245	42246	-	-	187.00	67.00	31.50	25.00
BSF									
3/16 - 32	40034	40035	40036	-	-	67.00	19.00	6.30	5.00
1/4 - 26	40044	40045	40056	-	-	72.00	22.00	8.00	6.30
5/16 - 22	40054	40055	40056	-	-	80.00	24.00	8.00	6.30
3/8 - 20	40064	40065	40066	-	-	85.00	25.00	8.00	6.30
7/16 - 18	40074	40075	40076	-	-	89.00	29.00	9.00	7.10
1/2 - 16	40084	40085	40086	-	-	95.00	30.00	11.20	9.00
9/16 - 16	40094	40095	40096	-	-	102.00	32.00	12.50	10.00
5/8 - 14	40104	40105	40106	-	-	112.00	37.00	14.00	11.20
3/4 - 12	40124	40125	40126	-	-	118.00	38.00	16.00	12.50
7/8 - 11	40144	40145	40146	-	-	135.00	48.00	20.00	16.00
1 - 10	40164	40165	40166	-	-	135.00	48.00	20.00	16.00
1 1/4 - 9	40184	40185	40186	-	-	151.00	51.00	22.40	18.00
BSC									
5/16 - 26	46504	46505	46506	-	-	73.000	22.000	9.000	7.100
3/8 - 26	46604	46605	46606	-	-	85.000	25.000	8.000	6.300
7/16 - 26	46704	46705	46706	-	-	89.000	29.000	9.000	7.100
1/2 - 26	46804	46805	46806	-	-	95.000	30.000	11.200	9.000
BSP									
1/8 - 28	41024	41025	41026	-	-	85.00	25.00	8.00	6.30
1/4 - 19	41044	41045	41046	-	-	95.00	30.00	11.20	9.00
3/8 - 19	41064	41065	41066	-	-	112.00	37.00	14.00	11.20
1/2 - 14	41084	41085	41086	-	-	130.00	45.00	18.00	14.00
5/8 - 14	41104	41105	41106	-	-	130.00	42.00	18.00	14.00
3/4 - 14	41124	41125	41126	-	-	135.00	48.00	20.00	16.00
1 - 11	41164	41165	41166	-	-	162.00	57.00	25.00	20.00

Note: Tap dimensions are based on American standard (ISO)Standard. Dimensions are in millimeters.

Dimensions are reference only and may be changed without notice.

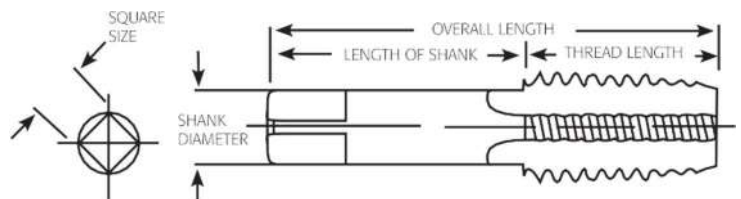

Recoil® STI Taps - Part Numbers and Dimensions

Thread Size	Taper	Intermediate	Bottoming	Spiral Point	Spiral Flute	Overall Length	Thread Length	Shank Diameter	Square Drive
BA						Dimensions in mm			
0 BA	40504	40505	40506	-	-	72.00	22.00	8.00	6.30
1 BA	40514	40515	40516	-	-	66.00	19.00	6.30	5.00
2 BA	40524	40525	40526	-	-	66.00	19.00	6.30	5.00
4 BA	40544	40545	40546	-	-	53.00	13.00	4.50	3.55
6 BA	40564	40565	40566	-	-	50.00	13.00	3.55	2.80
NPT ANSI		American ANSI B94.9		NPT		Dimensions in Inches			
1/8 - 27	46025	46026	-	-	-	2 1/8	3/4	0.438	0.328
1/4 - 18	46045	46046	-	-	-	2 7/16	1 1/16	0.563	0.420
3/8 - 18	46065	46066	-	-	-	2 9/16	1 1/6	0.700	0.531
1/2 - 14	46085	46086	-	-	-	3 5/32	1 3/8	0.687	0.515
3/4 - 14	46125	46126	-	-	-	3 9/32	1 3/8	0.906	0.679
1 - 11 1/2	46165	46166	-	-	-	3 3/4	4 3/4	1.125	0.893
8 TPI UN						Dimensions in Inches			
1 1/8 - 8	46184	46185	46186	-	-	5.945	2.007	0.881	0.708
1 1/4 - 8	46204	46205	46206	-	-	6.378	2.244	0.984	0.787
1 3/8 - 8	46224	46225	46226	-	-	6.692	2.362	1.102	0.881
1 1/2 - 8	46244	46245	46246	-	-	6.692	2.362	1.102	0.881
1 5/8 - 8	46264	46265	46266	-	-	7.362	2.637	1.240	0.984
1 3/4 - 8	46284	46285	46286	-	-	7.362	2.637	1.240	0.984
1 7/8 - 8	46304	46305	46306	-	-	7.874	2.755	1.397	1.102
2 - 8	46324	46345	46326	-	-	7.874	2.755	1.397	1.102

Note: The taps listed above represent the most popular of the Recoil taps available. Other sizes and types are available including BSW,BSF, NPT, BA, 8UN etc.

Tap dimensions based upon international (ISO) standard. Dimensions are reference only and may be changed without notice.



Recoil® STI Thread Gauges

Thread gauging is recommended wherever precision threads are required. The quality of the tapped hole which accommodates the insert determines the finished size and hole quality after the insert has been installed. If the finished tapped hole gauges satisfactorily, the installed insert will be within the thread tolerance.

Thread / Tolerance	Close	Medium
Metric	4H5H	5H
UN	3B	2B
Imperial	Close	Medium

Technical Information

Recoil gauges 1/2" M12 and below have at least a .0002" or 5µm wear allowance on the Go nib. Gauge handle and all gauge nibs are marked with the extreme product limits for particular size and class of fit. Where precision is required, 3B gauges should be used. When using locking inserts, 3B gauges should be used as close precision is required.

Thread Pitch Gauges



Fits and Tolerances

Recoil gauges are supplied for two different classes of fit (tolerances). These are close and medium tolerance. Gauges are used to check the pitch diameter of the tapped hole; the "NoGo" end of the gauge checks the pitch diameter is not too large and the "Go" end checks the pitch diameter is not too small.

Recoil® STI Gauges - Part Numbers

Nominal Thread Size	Working Gauges	
	3B Close Fit Unified Coarse	2B Medium Fit
#2 (.086) - 56	63523	63522
#3 (.099) - 48	63533	63532
#4 (.112) - 40	63543	63542
#5 (.125) - 40	63553	63552
#6 (.138) - 32	63563	63562
#8 (.138) - 32	63583	63582
#10 (.190) - 24	63603	63602
#12 (.216) - 24	63623	63622
1/4 (.2500) - 20	63043	63042
5/16 (.3125) - 18	63053	63052
3/8 (.3750) - 16	63063	63062
7/16 (.4375) - 14	63073	63072
1/2 (.5000) - 13	63083	63082
9/16 (.5625) - 12	63093	63092
5/8 (.6250) - 11	63103	63102
11/16 (.6875) - 11	63113	63112
3/4 (.7500) - 10	63123	63122
7/8 (.8750) - 9	63143	63142
1 (1.0000) - 8	63163	63162
1-1/8 (1.1250) - 7	63183	63182
1-1/4 (1.2500) - 7	63203	63202
1-3/8 (1.3750) - 6	63223	63222
1-1/2 (1.5000) - 6	63243	63242

Nominal Thread Size	Working Gauges	
	3B Close Fit Unified Fine	2B Medium Fit
#3 (.099) - 56	64533	64532
#4 (.112) - 48	64543	64542
#6 (.138) - 40	64563	64562
#8 (.164) - 36	64583	64582
#10 (.190) - 32	64603	64602
1/4 (.2500) - 28	64043	64042
5/16 (.3125) - 24	64053	64052
3/8 (.3750) - 24	64063	64062
7/16 (.4375) - 20	64073	64072
1/2 (.5000) - 20	64083	64082
9/16 (.5625) - 18	64093	64092
5/8 (.6250) - 18	64103	64102
3/4 (.7500) - 16	64123	64122
7/8 (.8750) - 14	64143	64142
1 (1.0000) - 12	64163	64162
1 (1.0000) - 14	64163-14	64162-14
1-1/8 (1.1250) - 12	64183	64182
1-1/4 (1.2500) - 12	64203	64202
1-3/8 (1.3750) - 12	64223	64222
1-1/2 (1.5000) - 12	64243	64242

Recoil® STI Gauges - Part Numbers

Nominal Thread Size	Working Gauges	
	4H/5H Close Fit	5H Medium Fit
	Metric Coarse	
M2 - 0.4	65024	65025
M2.2 - 0.45	65014	65015
M2.5 - 0.45	65254	65255
M3 - 0.5	65034	65035
M3.5 - 0.6	65354	65355
M4 - 0.7	65044	65045
M5 - 0.8	65054	65055
M6 - 1.0	65064	65065
M7 - 1.0	65074	65075
M8 - 1.25	65084	65085
M9 - 1.25	65094	65095
M10 - 1.5	65104	65105
M11 - 1.5	65114	65115
M12 - 1.75	65124	65125
M13 - 1.75	65134	65135
M14 - 2.0	65144	65145
M15 - 2.0	65154	65155
M16 - 2.0	65164	65165
M18 - 2.5	65184	65185
M20 - 2.5	65204	65205
M22 - 2.5	65224	65225
M24 - 3.0	65244	65245
M27 - 3.0	65274	65275
M30 - 3.5	65304	65305
M30 - 3.0	65304-3	65305-3
M36 - 4.0	65364	65365
M39 - 4.0	65394	65395
M42 - 4.5	65424	65425
M42 - 4.0	65424-4	65425-4

Nominal Thread Size	Working Gauges	
	4H/5H Close Fit	5H Medium Fit
	Metric Fine	
M8 - 1.0	67084	67085
M10 - 1.0	68104	68105
M10 - 1.25	67104	67105
M11 - 1.0	68114	68115
M11 - 1.25	67114	67115
M12 - 1.25	68124	68125
M12 - 1.5	67124	67125
M13 - 1.25	68134	68135
M13 - 1.5	67134	67135
M14 - 1.5	67144	67145
M15 - 1.5	67154	67155
M16 - 1.5	67164	67165
M18 - 1.5	68184	68185
M18 - 2.0	67184	67185
M20 - 1.5	68204	68205
M20 - 2.0	67204	67205
M22 - 1.5	68224	68225
M22 - 2.0	67224	67225
M24 - 1.5	68244	68245
M24 - 2.0	67244	67245
M26 - 1.5	68264	68265
M27 - 1.5	68274	68275
M27 - 2.0	67274	67275
M30 - 1.5	68304	68305
M30 - 2.0	67304	67305
M36 - 1.5	68364	68365
M36 - 3.0	67364	67365
M39 - 2.0	68394	68395
M39 - 3.0	67394	67395
M42 - 2.0	68424	68425
M42 - 3.0	67424	67425



Recoil® Driver Tools

The Recoil range of power tooling ensures consistent high volume thread insert installation for a variety of applications. Recoil powered installation tools may be supplied for use with either a compressed

air supply or via a stabilized low voltage power supply to suit your particular requirements. Both equipment types offer significant productivity gains for high volume insert use.

REC-10K Air Driver

For installation of both Tanged and Tangless thread inserts, the REC- 10K with air motor includes small and large adaptors to fit Recoil Front End Assemblies (FEA) from M2.5 to M16 or #2-56 - 5/8",

and an adaptor to suit 1/4" hex drive mandrels. The air regulator, lubricator and gauge help clean the air and govern the amount of lubricant for the air motor.

- Both large and small adaptors
- 2 manual spanners for adaptors
- Standard 1/4" hex drive
- Air regulator, lubricator and gauge
- Hose
- Screwdriver
- Manual with parts list
- CE certified
- Hard Shell Case



REC-12 Electric Driver

The REC-12 Electric Driver is lightweight and designed for installation of Tanged and Tangless thread inserts.

- Auto reverse
- Used for Tanged and Tangless Thread Inserts and Tooling
- Bulk inserts (HEX Electric Mandrel)
 - Installs up to M12 or 1/2"
- Stripfeed inserts (HEX FEA & Adaptor)
 - Installs M2.5 to M6
- Low and High speed function



REC-20 Battery Driver

The REC-20 is a lightweight portable battery powered driver for small production and hard to reach tapped hole applications. Operates either vertically or horizontally in two speeds. Use for Recoil Tanged and Tangless insert sizes M2-M8" or #2-56 - 3/8"

- Includes a spare battery
- Suits 1/4" hex drive or round shaft
- High and low speeds
- Forward and reverse directions
- Clutch torque controller
- CE Certified
- Hard shell case



Recoil® Tooling Options

There are a number of options for installing Tangless® and Tanged inserts—using a prewinder, hand/electric tools, or pneumatic tools. The optimal selection of tooling is based on the type of application and how many inserts will be installed.

To select tools and components for a new system, or as replacement parts, use this chart to ensure the accuracy of your order.

Recoil Thread Insert Tooling Part Numbering System

Diagram of Recoil Thread Insert Tooling Part Number Example - M8-1.25

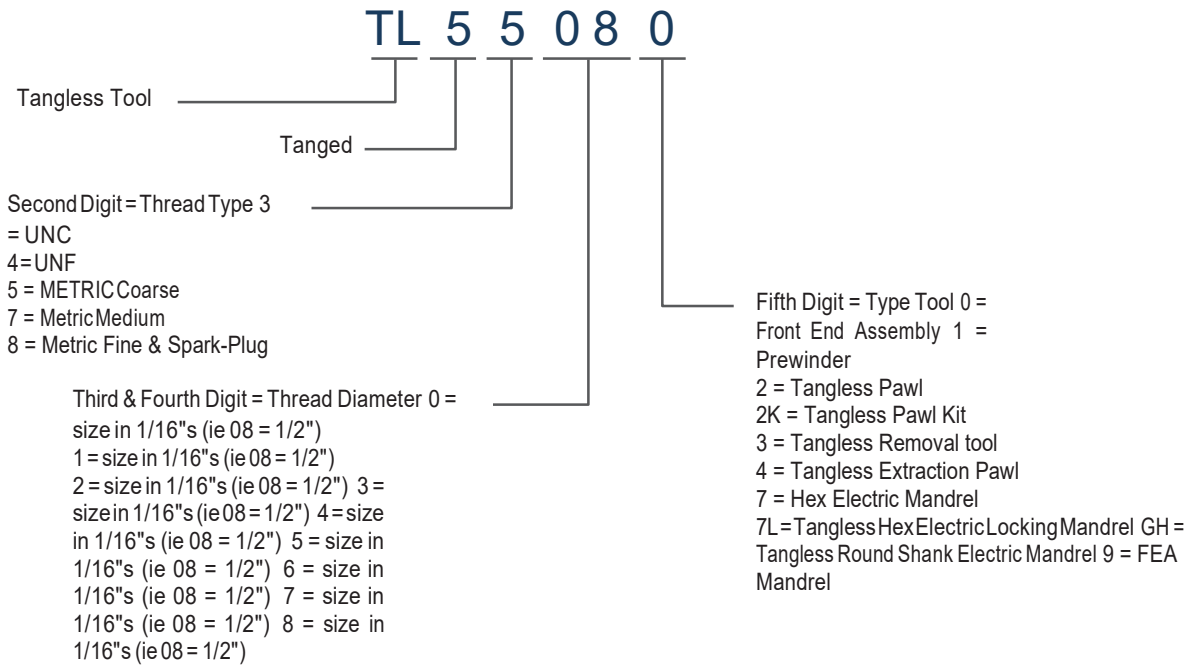

Example-Tangless M8-1.25 Front end assembly



REC-10K AirDriver

Pneumatic PowerTooling

- Wide thread size range #2-56 through 3/4", or M2.5 through M16, coarse and fine
- Rugged and versatile air motor
- May be used with captive strip feed or bulk insert insertion
- Standard speed 1500 rpm
- Reverse by trigger. The complete pneumatic insert installation tool comprises three components:
 - Air motor with single lever control to install and retract
 - Adaptor - connect the motor to the insert driven nozzle
 - Small and large types
- Front end assembly nozzle to suit the particular insert thread size

Compressed Air Supply for Pneumatic Installation Tools chart

Pressure Recommendations for Insert Sizes										
Inch	#2 #4	#5	#6	#8 #10	1/4"	5/16"	3/8"	7/16"	1/2"	
Metric	M2 - 2.5, M2.5	M3	M3.5	M4, M5	M6, M7	M8	M10	-	M12	
Recommended Pressure										
psi	25	20 - 30	25 - 30	40	45	50 - 60	60	70	70 - 80	90
bar	1.70	1.3 - 2.0	1.7 - 2.0	2.72	3.06	3.4 - 4.0	4.0	4.76	4.7 - 5.4	6.0
MPa	0.172	0.138 - 0.206	0.172 - 0.206	0.275	0.310	0.344 - 0.413	0.413	0.482	0.482 - 0.551	0.620

If difficulty is encountered within the above settings, reduce the pressure until the optimum setting is found. It is imperative that a regulated moisture-free and filtered air supply is used with all Recoil® pneumatic tooling. Reliability will be affected if an adequate and regulated air supply is not used with these tools. Guidelines for typical Recoil insert tool pressure requirements are shown above.



REC-10K Air Driver

For installation of both Tanged and Tangless® thread inserts, the REC- 10K with air motor includes small and large adaptors to fit Recoil® Front End Assemblies (FEA) from M2.5 to M16 or #2-56 - 5/8",

- Small & Large Adaptor to suit size range FEA
- Standard 1/4" Hex Drive to suit size range M2 - M12 or #2-56 - 1/2"
- 2 manual spanners for adaptors
- Air regulator, lubricator and gauge

To install using air tooling all you need is:

- Air Motor Hex** REC-10K
- Air Motor Adapter, Small** (M2.5 to M6) and (#2-56 to 1/4")
- Air Motor Adapter, Large** (M8 to M14) and (5/16 to 3/4")
- Front End Assembly** Choose from the tables from page 84 depending on your thread form and diameter

and an adaptor to suit 1/4" hex drive mandrels. The air regulator, lubricator and gauge help clean the air and govern the amount of lubricant for the air motor.

- Hose
- Screwdriver
- Manual with parts list
- CE certified
- Hard Shell Case

Note: Use for Tanged and Tangless thread inserts. Free Running and Locking inserts. For Bulk or Stripfeed inserts.

Service Kit Part No. REC10K-TK

Installation Tooling Guide

- Used with Small and Large Adaptor Part No. TL5___0 or 5___0
- Used with Hex Installation Mandrel (Use with Hex Adaptor only) Part No. TL5___7 or 5___7





Recoil® Front End Assembly (FEA) Part Numbers - Tanged and Tangless®

Thread Size	Tangless		Tanged		Mandrel
	Front End Assembly Part Number	Replacement Pawl Kit Part Number	Front End Assembly Part Number	Front End Assembly Nozzle	
Metric Coarse					
M2.2 - 0.45	-	-	55250	55258	55259
M2.5 - 0.45	TL55250	TL55252K	55250	55258	55259
M3 - 0.5	TL55030	TL55032K	M8751-3-15	M8769-3-15	M8757-3
M3.5 - 0.6	TL55040	-	M8751-3.5-15	M8769-3.5-15	M8757-3.5
M4 - 0.7	TL55050	TL55042K	M8751-4-15	M8769-4-15	M8757-4
M5 - 0.8	TL55060	TL55052K	M8751-5-15	M8769-5-15	M8757-5
M6 - 1	-	TL55062K	M8751-6-15	M8769-6-15	M8757-6
M7 - 1	-	-	55070	55078	55079
M8 - 1.25	TL55080	TL55082K	M8751-8-15	M8769-8-15	M8757-8
M10 - 1.5	TL55100*	TL55102K*	M8751-10-15	M8769-10-15	M8757-10
M12 - 1.75	TL55120*	TL55122K*	M8751-12-15	M8769-12-15	M8757-12
M16 - 2	-	-	55160	55168	55169
Metric Fine					
M8 - 1	-	-	57080	57088	57089
M10 - 1	-	-	58100	58108	58109
M10 - 1.25	-	-	57100	57108	57109
M12 - 1.25	-	-	58120	58128	58129
M12 - 1.5	-	-	57120	57128	57129
M14 - 1.5	-	-	M8753-14	M8773-14	M8774-14
Unified Coarse					
#2 - 56	TL53520	TL53522K	53520	53528	53529
#4 - 40	TL53540	TL53542K	M8551-04-15	M8557-04-15	M8553-04
#5 - 40	-	-	M8851-05-15	M8557-05-15	M8553-05
#6 - 32	TL53560	TL53562K	M8551-06-15	M8557-06-15	M8553-06
#8 - 32	TL53580	TL53582K	M8551-2-15	M8557-2-15	M8553-2
#10 - 24	TL53600*	TL53602K*	M8551-3-15	M8557-3-15	M8553-3
1/4 - 20	TL53040*	TL53042K*	M8551-4-15	M8557-4-15	M8553-4
5/16 - 18	TL53050*	TL53052K*	M8251-5-15	M8257-5-15	M8253-5
3/8 - 16	TL53060*	TL53062K*	M8251-6-16	M8257-6-15	M8253-6
7/16 - 14	-	-	M8251-7-15	M8257-7-15	M8253-7
1/2 - 13	-	-	M8251-8-15	M8257-8-15	M8253-8
5/8 - 11	-	-	53100	53108	53109
3/4 - 10	-	-	53120	53128	53129
Unified Fine					
#6 - 40	-	-	54560	54568	54569
#10 - 32	TL54600	TL54602K	M8552-3-15	M8558-3-15	M8554-3
1/4 - 28	TL54040	TL54042K	M8552-4-15	M8558-4-15	M8554-4
5/16 - 24	TL54050	TL54052K	M8252-5-15	M8258-5-15	M8254-5
3/8 - 24	TL54060	TL54062K	54060	54068	54069
7/16 - 20	-	-	M8252-7-15	M8258-7-15	M8254-7
1/2 - 20	-	-	M8252-8-15	M8258-8-15	M8254-8
5/8 - 18	-	-	M8252-9	M8258-9	M8254-9
3/4 - 16	-	-	54120	54128	54129

Recoil® Front End Assembly (FEA) Tool Dimensions

Part number	Information			ToolDimensions					
	Current	Standard	Size (Thread - Pitch) Adaptor Metric	Length A	Length B	Diam C	Diam D	Diam E	Length F
TL55250	Tangless Metric	M2.5 - 0.45	M8550R (Small)	278	24	3	10	34	71
55250	Metric	M2.5 - 0.45	M8550R (Small)	-	25.9	-	10	34	71
TL55030	Tangless Metric	M3 - 0.5		278	24	5	10	34	71
M8751-3-15	Metric	M3 - 0.5		-	25.9	7.1	10	34	71
M8751-3.5-15	Metric	M3.5 - 0.6		-	25.9	7.9	10	34	71
TL55040	Tangless Metric	M4 - 0.7		280	24	6	13	34	71
M8751-4-15	Metric	M4 - 0.7		-	25.9	8.75	13	34	71
TL55050	Tangless Metric	M5 - 0.8		282	27	7	13	34	71
M8751-5-15	Metric	M5 - 0.8		-	25.9	9.52	13	34	71
TL55060	Tangless Metric	M6 - 1		282	42	8	16	34	71
M8751-6-15	Metric	M6 - 1		-	42.15	10.65	16	34	71
55070	Metric	M7 - 1		-	39.6	11.9	18.3	34	71
TL55080	Tangless Metric	M8 - 1.25	M85501R (Large)	300	33	11	20	40	83
M8751-8-15	Metric	M8 - 1.25	M85501R (Large)	-	35.55	14.3	19	40	83
57080	Metric	M8 - 1	M85501R (Large)	-	35.55	14.3	19	40	83
TL55100	Tangless Metric	M10 - 1.5		310	55	13	23	40	83
M8751-10-15	Metric	M10 - 1.5		-	55.6	15.9	22.2	40	83
58100	Metric	M10 - 1		-	52.45	15.9	22.2	40	83
TL55120	Tangless Metric	M12 - 1.75		320	66	15	25	34	83
M8751-12-15	Metric	M12 - 1.75		-	55.75	-	20.6	34	83
58120	Metric	M12 - 1.25		-	54.35	-	20.6	34	83
57120	Metric	M12 - 1.5		-	55.75	-	20.6	34	83
M8753-14	Metric	M14 - 1.5		-	-	25	25	34	83
55160	Metric	M16 - 2		-	-	25	25	34	83
Unified Coarse									
TL53520	Tangless Unified Coarse	UNC #2 - 56	M8550R (Small)	278	24	3	10	34	71
53520	Unified Coarse	UNC #2 - 56	M8550R (Small)	-	24	4.60	8.70	34	71
TL53540	Tangless Unified Coarse	UNC #4 - 40		278	24	5	10	34	71
M8551-04-15	Unified Coarse	UNC #4 - 40		-	27.7	6.60	10	34	71
M8551-05-15	Unified Coarse	UNC #5 - 40		-	28	7	10	34	71
TL53560	Tangless Unified Coarse	UNC #6 - 32		278	29	6	13	34	71
M8551-06-15	Unified Coarse	UNC #6 - 32		-	31.7	7.90	13	34	71
TL53580	Tangless Unified Coarse	UNC #8 - 32		280	29	6	13	34	71
M8551-2-15	Unified Coarse	UNC #8 - 32		-	26.7	8.90	13	34	71
TL53600	Tangless Unified Coarse	UNC #10 - 24		282	24	7	13	34	71
M8551-3-15	Unified Coarse	UNC #10 - 24		-	34	9.40	13	34	71
TL53040	Tangless Unified Coarse	UNC 1/4" - 20		282	36	9	16	34	71
M8551-4-15	Tangless Unified Coarse	UNC 1/4" - 20		282	36.6	10.70	16	34	71
TL53050	Tangless Unified Coarse	UNC 5/16" - 18	M85501R (Large)	300	31	11	20	40	83
M8551-5-15	Unified Coarse	UNC 5/16" - 18	M85501R (Large)	-	31.75	14	19	40	83
TL53060	Tangless Unified Coarse	UNC 3/8" - 16		320	50	12	23	40	83
M8551-6-15	Unified Coarse	UNC 3/8" - 16		-	51	17.5	22.3	40	83
M8551-7-15	Unified Coarse	UNC 7/16" - 14		-	47.5	19	19	40	83

Recoil® Front End Assembly (FEA) Tool Dimensions

Part number	Information			ToolDimensions						
	Current	Standard	Size (Thread - Pitch)	Adaptor	Length A	Length B	Diam C	Diam D	Diam E	Length F
M8551-8-15		Unified Coarse	UNC 1/2" - 13		-	56	20.6	20.6	40	83
53100		Unified Coarse	UNC 5/8" - 11		-	50	12	23	40	-
53120		Unified Coarse	UNC 3/4" - 10		-	121	28	28	40	-
Unified Fine										
54560		Unified Fine	UNF #6 - 40		-	26	8	12.7	40	-
TL54600		Unified Fine	UNF #10 - 32	M8550R (Small)	282	31	7	13	34	71
M8551-04-15		Unified Fine	UNF #10 - 32	M8550R (Small)	-	26	9.6	13	34	71
TL54040		Unified Fine	UNF 1/4" - 28		282	36	8	16	34	71
M8551-04-15		Unified Fine	UNF 1/4" - 28		-	31	11	16	34	71
TL54050		Unified Fine	UNF 5/16" - 24	M85501R (Large)	320	28	11	20	40	83
M8551-04-15		Unified Fine	UNF 5/16" - 24	M85501R (Large)	-	49	14	19	40	83
TL54060		Unified Fine	UNF 3/8" - 24		320	50	12	23	40	83
M8551-04-15		Unified Fine	UNF 3/8" - 24		-	52	17.5	21	40	83
M8252-7-15		Unified Fine	UNF 7/16" - 20		-	47.5	19	19	40	83
M8252-8-15		Unified Fine	UNF 1/2" - 20		-	58.5	21	21	40	83
M8252-9		Unified Fine	UNF 5/8" - 18		-	115	25	25	40	83
54120		Unified Fine	UNF 3/4" - 16		-	121	28	28	40	83

Dimensions are in "mm" unless otherwise stated. Dimensions provided for reference only.

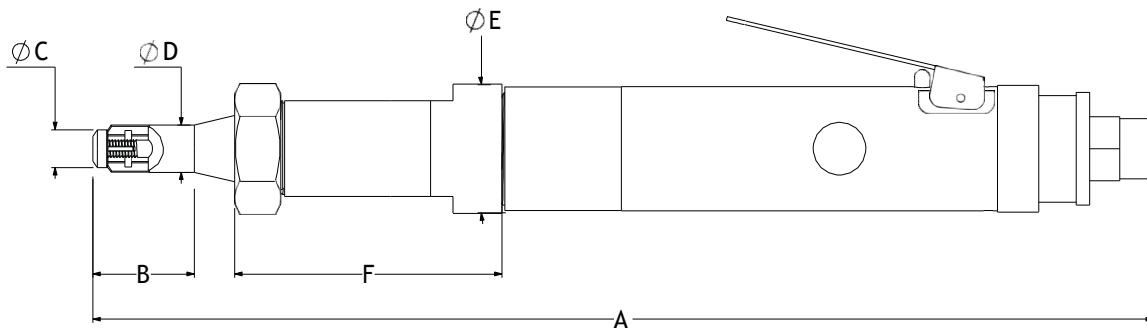

REC-12 Electric Driver

The REC-12 Electric driver is designed for low or high volume production environment and used for Recoil® Tanged and Tangless® bulk or strip feed products.

Key features

- Light weight
- Auto reverse
- Used for Tanged and Tangless Thread Inserts and Tooling
- Bulk inserts (HEX Electric Mandrel)
 - Installs up to M12 or 1/2" using Hex Installation Mandrel
 - Installs up to M6 using Tangless Hex FEA
- Strip feed inserts (HEX FEA & Adaptor)
 - Installs M2.5 to M6
- Low and High speed function

Installation Tooling Guide

- Tanged Hex Installation Tool Part No. 5___7
- Tangless Hex Installation Tool Part No. TL 5___7
- Tangless Hex Removal Tool Part No. TL 5___3
- Tangless Hex Front End Assembly (Used with Adaptor)



Power Supply and Installation Drivers

Size	Part Number	Alternate Number
Install Driver #2 - #8	REC-12	KFS-12
Install Driver #10 - 1/4"		CT5407
Power Supply Adaptor		

Part No. REC-12

Kit contents	Quantity
Electric Driver	1
Transformer	1
Hex Front End Assembly Adaptor (FEA)	1
Manual	1
Power Cable	1

Part No. to Order

Region	Part No.
U.S (Japan, Sth.Korea, China)	REC-12US
U.K	REC-12UK
Australia	REC-12AUS
Europe	REC-12EU

REC-20 Battery Driver

The REC-20 is a lightweight portable battery powered driver for small production and hard to reach tapped hole applications. Operates

- Includes a spare battery
- Suits 1/4" hex drive or round shaft
- High and low speeds
- Forward and reverse directions

either vertically or horizontally in two speeds. Use for Recoil® Tanged and Tangless® insert sizes M2-M8" or #2-56 - 3/8".

- Clutch torque controller
- CE Certified
- Hard shell case

REC-20 Battery Driver Part Number

Part No. REC-20-US

Kit contents	Quantity
Cordless Driver	1
Battery	2
Battery Charger	1
1/4" Hex Chuck	1

Part No. REC-20-AUS

Kit contents	Quantity
Cordless Driver	1
Battery	2
Battery Charger	1

Part No. REC-20-USP

Kit contents	Quantity
Cordless Driver	1
Battery	2
Battery Charger	1

Part No. REC-10K

Kit contents	Quantity
Standard 1/4" Hex Drive.	1
Small Adaptor to suit FEA	1
Large Adaptor to suit FEA	1
Air regulator	1
Lubricator	1
Gauge	1
Hose	1
Screwdriver	1
Spanners for adaptors	2
Manual with parts list	1

Part No. REC-20-EUR

Kit contents	Quantity
Cordless Driver	1
Battery	2
Battery Charger	1

Part No. REC-20-UK

Kit contents	Quantity
Cordless Driver	1
Battery	2
Battery Charger	1

- Tangless Round Shank Installation Tool Part No. TL 5___7GH
(Used with 1/4" Hex Chuck)

1/4" Hex Chuck Pa
No. CK10AC-HEX
(Optional)



Battery Part
No.
B30111815



Recoil® Hex Installation Tool

Recoil Tangless® Hex Installation Tool

Part Number		Information			Mandrel Dimensions				Collar Dimensions	
Current ¹	Alternate	Type	Standard	Size (Thread - Pitch)	Length A	Length B ²	Diam C	Hex Drive D	Diam E	Diam F
TL55257	2KHEM-F2.5	Free Running	Metric	M2.5 - 0.45	69	9	2	1/4"	10	6
TL55037	2KHEM-F3	Free Running	Metric	M3 - 0.5	69	10	3	1/4"	10	7
TL55047	2KHEM-F4	Free Running	Metric	M4 - 0.7	76	14	4	1/4"	11	9
TL55057	2KHEM-F5	Free Running	Metric	M5 - 0.8	79	17	5	1/4"	11	10
TL55067	2KHEM-F6	Free Running	Metric	M6 - 1.0	78	20	6	1/4"	11	11
TL55087	2KHEM-F8	Free Running	Metric	M8 - 1.25	99	29	8	1/4"	13	13
TL55107	2KHEM-F10	Free Running	Metric	M10 - 1.5	105	35	10	1/4"	16	16
TL55127	2KHEM-F12	Free Running	Metric	M12 - 1.75	115	40	11	1/4"	18	18
TL55147	-	Free Running	Metric	M14 - 2.0	115	85	14	1/4"	20	20
TL55167	2KHEM-F16	Free Running	Metric	M16 - 2.0	122	92	16	1/4"	24	24
TL53527	2KHEC-02	Free Running	Unified Coarse	UNC #2 - 56	70	10	2	1/4"	10	6
TL53547	2KHEC-04	Free Running	Unified Coarse	UNC #4 - 40	72	10	3	1/4"	10	6
TL53567	2KHEC-06	Free Running	Unified Coarse	UNC #6 - 32	76	15	3	1/4"	10	8
TL53587	2KHEC-2	Free Running	Unified Coarse	UNC #8 - 32	76	16	4	1/4"	10	8
TL53607*	2KHEC-3	Free Running	Unified Coarse	UNC #10 - 24	68	13	5	1/4"	10	6
TL53047	2KHEC-4	Free Running	Unified Coarse	UNC 1/4" - 20	61	26	6	1/4"	10	6
TL53057	2KHEC-5	Free Running	Unified Coarse	UNC 5/16" - 18	89	30	7	1/4"	18	18
TL53067	2KHEC-6	Free Running	Unified Coarse	UNC 3/8" - 16	94	30	9	1/4"	18	18
TL53077	2KHEC-7	Free Running	Unified Coarse	UNC 1/2" - 13	120	43	12	1/4"	20	20
TL54607	2KHEF-F3	Free Running	Unified Fine	UNF #10 - 32	73	19	5	1/4"	10	8
TL54607L	2KHEF-L3	Locking	Unified Fine	UNF #10 - 32	73	19	5	1/4"	10	8

Dimensions are in "mm" unless otherwise stated. Dimensions provided for reference only.

¹ May not be compatible with all styles of Tangless tooling.

² Maximum length possible when collar is adjusted.

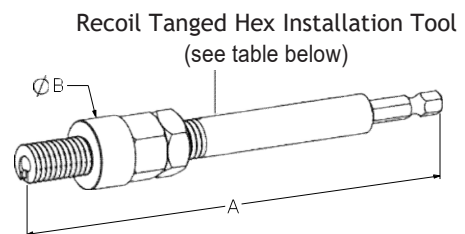
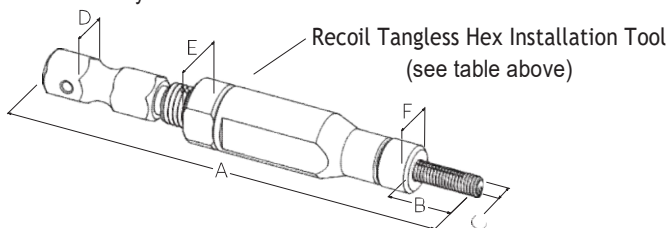

Recoil Tanged Hex Installation Tool

RecoilPartNo.	Size	A	B
53527	#2 - 56UNC	100	8
53547	#4 - 40UNC	100	8
53557	#5 - 40UNC	100	8
53567	#6 - 32UNC	100	8
53587	#8 - 32UNC	100	8
53607	#10 - 24UNC	100	8
53047	1/4" - 20UNC	100	13
53057	5/16" - 18UNC	100	14
53067	3/8" - 16UNC	100	14
54607	#10 - 32UNF	100	10

RecoilPartNo.	Size	A	B
54047	1/4" - 28 UNF	100	11
55027	M2 - 0.4	100	8
55257	M2.5 - 0.45	100	8
55037	M3 - 0.5	100	8
55357	M3.5 - 0.6	100	8
55047	M4 - 0.7	100	8
55057	M5 - 0.8	100	10
55067	M6 - 1.0	100	11
55087	M8 - 1.25	100	14
55107	M10 - 1.5	100	14

Recoil® Hex Electric Tool Part Numbers - Tanged and Tangless®

Thread Size/Pitch	Hex Electric Tool	Tangless		Tanged
		Hex Electric Locking Tool	Replacement Pawl	Hand Prewinder Tool
Metric				
M2.2 - 0.45	-	-	-	55011
M2 - 0.4	-	-	-	55021
M2.5 - 0.45	TL55257	2KHEM-L2.5	TL55252K	55257
M3 - 0.5	TL55037	2KHEM-L3	TL55032K	55037
M3.5 - 0.6	-	-	-	55357
M4 - 0.7	TL55047	2KHEM-L4	TL55042K	55047
M5 - 0.8	TL55057	2KHEM-L5	TL55052K	55057
M6 - 1	TL55067	2KHEM-L6	TL55062K	55067
M7 - 1.0	-	-	-	-
M8 - 1.25	TL55087	2KHEM-L8	TL55082K	55087
M10 - 1.5	TL55107	2KHEM-L10	TL55102K	55107
M12 - 1.75	TL55127	2KHEM-L12	TL55122K	55127
Unified Coarse				
#2 - 56	TL53527	-	TL53522K	53527
#3 - 48	-	-	-	-
#4 - 40	TL53547	-	TL53542K	-
#5 - 40	-	-	-	53557
#6 - 32	TL53567	-	TL53562K	53567
#8 - 32	TL53587	-	TL53582K	53587
#10 - 24	2KHEC-3*	-	-	53607
#12 - 24	-	-	-	53627
1/4 - 20	TL53047	-	TL53042K	53047
5/16 - 18	TL53057	-	-	53057
3/8 - 16	TL53067	-	-	53067
7/16 - 14	-	-	-	53077
1/2 - 13	TL53087	-	TL53082K	53087
Unified Fine				
#3 - 56	-	-	-	-
#4 - 48	-	-	-	-
#6 - 40	-	-	-	-
#8 - 36	-	-	-	-
#10 - 32	TL54601	TL54607L	TL54602K	54601
1/4 - 28	TL54041	-	TL54042K	54041
5/16 - 24	2KPHF-5*	-	-	54051
3/8 - 24	2KPHF-6*	-	-	54061
7/16 - 20	-	-	-	54071
1/2 - 20	-	-	-	54081



Recoil® Tangless® Round Installation Tool

Hand Installation Handles

Description	Part Number	Alternate Number
Metal Gage-Style Handle	TL5000	2KHEU-UI



Tangless Manual Installation Tool



Gage Style Handle

Recoil Round Installation Tool

Round Installation Tool		
Size	Part Number	Alternate Number
Inch		
UNC #2-56	TL53527GH	2KREC-02
UNC #4-40	TL53547GH	2KREC-04
UNC #6-32	TL53567GH	2KREC-06
UNC #8-32	TL53587GH	2KREC-2
UNC #10-24	2KREC-3	-
UNC 1/4-20	TL53047GH	2KREC-4
UNC 5/16-18	TL53057GH	2KREC-5
UNC 3/8-16	TL53067GH	2KREC-6
UNF #10-32	TL54607GH	2KREF-F3
Metric		
M2-0.4	2KREM-F2	-
M2.5-0.45	TL55257GH	2KREM-F2.5
M3-0.5	TL55037GH	2KREM-F3
M4-0.7	TL55047GH	2KREM-F4
M5-0.8	TL55057GH	2KREM-F5
M6-1.0	TL55067GH	2KREM-F6
M8-1.25	TL55087GH	2KREM-F8
M10-1.5	TL55107GH	2KREM-F10
M12-1.75	TL55127GH	2KREM-F12

Round Installation Tool Spare Mandrel		
Size	Part Number	Alternate Number
Inch		
UNC #2-56	TL53527RM	2KREC-02M
UNC #4-40	TL53547RM	2KREC-04M
UNC #6-32	TL53567RM	2KREC-06M
UNC #8-32	TL53587RM	2KREC-2M
UNC #10-24	2KREC-3M	-
UNC 1/4-20	TL53047RM	2KREC-4M
UNC 5/16-18	TL53057RM	2KREC-5M
UNC 3/8-16	TL53067RM	2KREC-6M
UNF #10-32	TL54607RM	2KREF-F3M
Metric		
M2-0.4	2KREM-F2M	-
M2.5-0.45	TL55257RM	2KREM-F2.5M
M3-0.5	TL55037RM	2KREM-F3M
M4-0.7	TL55047RM	2KREM-F4M
M5-0.8	TL55057RM	2KREM-F5M
M6-1.0	TL55067RM	2KREM-F6M
M8-1.25	TL55087RM	2KREM-F8M
M10-1.5	TL55107RM	2KREM-F10M
M12-1.75	TL55127RM	2KREM-F12M

Round Installation Tool Spare Pawl		
Size	Part Number	Alternate Number
Inch		
UNC #2-56	TL53522	2KIPC-02
UNC #4-40	TL53542	2KIPC-04
UNC #6-32	TL53562	2KIPC-06
UNC #8-32	TL53582	2KIPC-2
UNC #10-24	2KIPC-3	-
UNC 1/4-20	TL53042	2KIPC-4
UNC 5/16-18	TL53052	2KIPC-5
UNC 3/8-16	TL53062	2KIPC-6
UNF #10-32	TL54602	2KIPF-3
UNF 1/4-28	TL54042	2KIPF-4
UNF 5/16-24	2KIPF-5	
UNF 3/8-24	2KIPF-6	
Metric		
M2-0.4	2KIPM-2	-
M2.5-0.45	TL55252	2KIPM-2.5
M3-0.5	TL55032	2KIPM-3
M4-0.7	TL55042	2KIPM-4
M5-0.8	TL55052	2KIPM-5
M6-1.0	TL55062	2KIPM-6
M8-1.25	TL55082	2KIPM-8
M10-1.5	TL55102	2KIPM-10
M12-1.75	TL55122	2KIPM-12

Recoil® Prewinder Installation Tools

This type of tool is ideal for installing inserts in small production runs or in areas where compressed air or electricity are not available and offers a quicker alternative to the simple hand installation tool. The tool is suitable for use when installing free running and locking inserts.

The mandrel is wound into the insert which is then installed into the tapped hole. During installation the insert diameter is reduced when passing through the bottom of the prewinder tool chamber making it easier to install. The mandrel is removed by turning the crank in a counter clockwise direction, leaving the insert in place.

Threaded Mandrel Type

The threaded mandrel type is suitable for the installation of free running and locking inserts. The mandrel is wound into the insert which is then wound into the tapped hole. The mandrel is removed by turning the crank in a counter clockwise direction, leaving the insert in place.

Note: The threaded mandrel type installation tool is recommended for installing locking inserts.

Note: Non Captive Prewinder – Installation tool with Pre-pressing cartridge Only for special utilisation and fine thread pitches.



Semi Production Pre-Winder Type Installation tool - Plastic Prewinder Type 3



Semi Production 'Pre-Winder' Non-Captive Type Installation Tool - Aluminium Body Type 5



Semi Production Pre-Winder Type Installation tool - Metal Body Type 4



Semi Production Threaded Mandrel Installation Tool Type 6

Recoil® Prewinder Hand Tool Part Numbers - Tanged and Tangless®

Thread Size/Pitch	Tangless		Tanged			
	Hand Prewinder Hand Tool	Replacement Pawl	Lightweight Prewinder Tool (3) Metric	Hand Prewinder Hand Tool (4)	Non Captive Prewinder Hand Tool (5)	Threaded Mandrel Tool (6)
M2 - 0.4	-	-	-	55021	-	-
M2.2 - 0.45	-	-	-	55011	-	-
M2.5 - 0.45	TL55251	TL55252K	-	55251	-	-
M3 - 0.5	TL55031	TL55032K	55032U	55031	-	-
M3.5 - 0.6	-	-	-	55351	-	-
M4 - 0.7	TL55041	TL55042K	55042U	55041	-	-
M5 - 0.8	TL55051	TL55052K	55052U	55051	-	-
M6 - 1	TL55061	TL55062K	55062U	55061	-	-
M7 - 1	-	-	-	55071	-	-
M8 - 1	-	-	-	57081	-	-
M8 - 1.25	TL55081	TL55082K	55082U	55081	-	-
M10 - 1	-	-	-	58101	-	-
M10 - 1.25	-	-	57102U	57101	-	-
M10 - 1.5	TL55101	TL55102K	55102U	55101	-	-
M12 - 1.25	-	-	-	58121	-	-
M12 - 1.5	-	-	57122U	57121	-	-
M12 - 1.75	TL55121	TL55122K	55122U	55121	-	-
M14 - 1.5	-	-	-	57141	-	-
M14 - 2	-	-	-	-	-	55146
M16 - 1.5	-	-	-	-	57161	-
M16 - 2	-	-	-	-	55161	55166
M18 - 1.5	-	-	-	57181	-	-
M27 - 2	-	-	-	-	57271	-
M36 - 3	-	-	-	-	57361	-
M42 - 3	-	-	-	-	57421	-
M42 - 4.5	-	-	-	-	55421	-
M52 - 3	-	-	-	-	57421	-

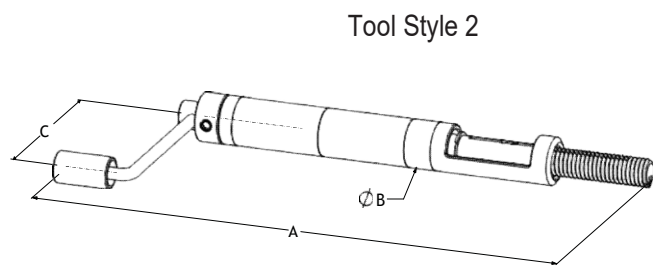
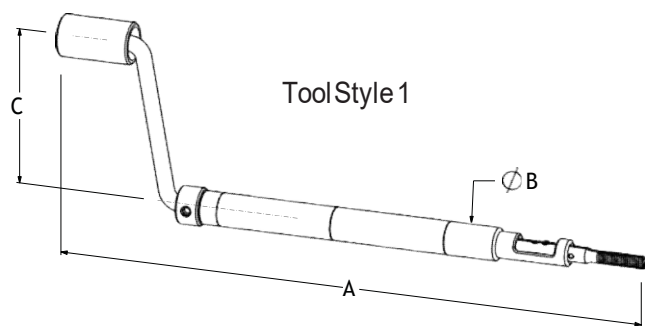



Recoil® Prewinder Hand Tool Part Numbers - Tanged and Tangless®

Thread Size/Pitch	Tangless		Tanged			
	Hand Prewinder Hand Tool	Replacement Pawl	Lightweight Prewinder Tool (3)	Hand Prewinder Hand Tool (4)	Non Captive Prewinder Hand Tool (5)	Threaded Mandrel Tool (6)
Unified Coarse						
#2 - 56	TL53521	TL53522K	53522U	53521	-	-
#3 - 48	-	-	53532U	53531	-	-
#4 - 40	TL53541	TL53542K	53542U	-	-	-
#5 - 40	-	-	53552U	53551	-	-
#6 - 32	TL53561	TL53562K	53562U	53561	-	-
#8 - 32	TL53581	TL53582K	53582U	53581	-	-
#10 - 24	2KPHC-3	-	53602U	53601	-	-
#12 - 24	-	-	53622U	53621	-	-
1/4 - 20	2KPHC-4	-	53042U	53041	-	-
5/16 - 18	2KPHC-5	-	53052U	53051	-	-
3/8 - 16	2KPHC-6	-	53062U	53061	-	-
7/16 - 14	-	-	53072U	53071	-	-
1/2 - 13	-	-	53082U	53081	-	-
9/16 - 12	-	-	-	-	-	53096
5/8 - 11	-	-	-	-	53101	53106
3/4 - 10	-	-	-	-	53121	53126
7/8 - 9	-	-	-	-	53141	53146
1 - 8	-	-	-	-	53161	53166
1 1/8 - 7	-	-	-	-	-	53186
1 1/4 - 7	-	-	-	-	-	53206
1 3/8 - 6	-	-	-	-	-	53226
1 1/2 - 6	-	-	-	-	-	53246
Unified Fine						
#3 - 56	-	-	54532U	54531	-	-
#4 - 48	-	-	54542U	54541	-	-
#6 - 40	-	-	54562U	54561	-	-
#8 - 36	-	-	54582U	54581	-	-
#10 - 32	TL54601	TL54602K	54602U	54601	-	-
1/4 - 28	TL54041	TL54042K	54042U	54041	-	-
5/16 - 24	2KPHF-5	-	54052U	54051	-	-
3/8 - 24	2KPHF-6	-	54062U	54061	-	-
7/16 - 20	-	-	54072U	54071	-	-
1/2 - 20	-	-	54082U	54081	-	-
9/16 - 18	-	-	-	-	54091	-
5/8 - 18	-	-	-	-	54101	-
3/4 - 16	-	-	-	-	54121	-
7/8 - 14	-	-	-	-	54141	-
1 - 12	-	-	-	-	54161	-
1 - 14	-	-	-	-	54171	-
1 1/8 - 12	-	-	-	-	54181	-

Recoil® Tang Break Tool

Pneumatic Tang Break Tool

The pneumatic tang break tool is designed for high volume applications where rapid, effortless tang removal is required on insert sizes up to 3/4" or M20. This tool works on the same basis as the spring loaded tool, except the pin punches downward when an air cylinder is actuated by the valve.

Recoil Tang Break Off Tools

Tang break off tools are available in hand, semi automatic spring type and pneumatic. The spring loaded and pneumatic tang break tools are recommended for removal of tangs in production applications. For large diameter fine thread inserts, e.g. M18-1.5 and above, 3/4-16 and above, the use of long nose pliers is an alternative method to break the tang.

Manual Tang Break Tool

The simple Recoil manual magnetic tang removal tool is suitable for low volume tang removal and is used for insert sizes up to 1/2" or M12. The magnet allows for easy retrieval of the tang.

On larger sizes the multipurpose Recoil installation and tang break tool should be used. For tang removal, the tool is simply lifted and turned 90°, which will put the slot at right angles to the tang, then pushed downward with a sharp blow.

Spring Loaded Tang Break Tool

Spring loaded tang break tools offer effective removal of insert tangs and are suited from medium to large insert usage. Being spring loaded this tool requires no external power source and is suitable for tang removal on insert sizes up to 1/2" or M12. This tool is a spring loaded punch and when the tool is pushed down, the pin punches downward breaking off the tang.

Recoil Tang Break Tool Part Numbers

Insert Size	Manual Tang Break	Spring (ATBO) Type	Pneumatic Type
#2-56, M2-0.4, M2.2-0.45	59060M	59061	-
#3-48, #3-56, 6BA, M2.5-0.45	59070M	59071	-
#4-40, #4-48	59080M	59081	-
#5-40, 1/8-40, M3-0.5	59090M	59091	-
#6-32, #6-40, 4BA, M3.5-0.6	59100M	59101	-
#8-32, #8-36, 5/32, M4-0.7	59130M	59121	-
#10-24, #3/16-24, 2BA	59140M	59141	-
#10-32, #12-24, #12-28, 3/16-32, M5-0.8	59160M	59141	-
1/4-20, 1/4-28, 1/4-20, 1/4-26, 1/4-24, 0BA, M6-1	59190M	59181	59192
5/16-18, M7-1	59220M	59241	59252
5/16-24, 5/16-22, 5/16-26, M8-1, M8-1.25	59250M	59241	59252
3/8-16, 3/8-24, 3/8-20, M9-1, M9-1.25, M10-1.5	59280M	59291	59252
3/8-26, 7/16-14, 7/16-20, 1/8 BSP/NPT, M10-1, M10-1.25	59310M	59291	59252
7/16-14BSW, 7/16-18BSF, 7/16-16, 7/16-26, M11-1, M11-1.25, M11-1.5	59340M	-	-
1/2-13, 1/2-20, 1/2-12, 1/2-16, 1/2-26, M12-1, M12-1.25, M12-1.5, M12-1.75	59380M	59331	59332
M14-1.5	-	-	59462



Recoil® Removal Tool

Should inserts need to be removed, the use of the Recoil extraction tool is recommended. Extraction tools are simple and easy to use. As correct positioning will make the extraction easier, the tool should be turned 90° from the start of the coil allowing easy winding out of the insert. If the extraction tool is not gripping the insert, the edges can be resharpenered.

Size of extraction tool and related size inserts			
Size	Inch	Metric	Part No.
No.2	4-40 - 3/8	M3 - M10	50002
No.3	6-32 - 1	M4 - M24	50003
No.4	1 1/8 - 1/2	M27 - M39	50004
No.5	1 1/2 - 2 1/2	M8 - M65	50005

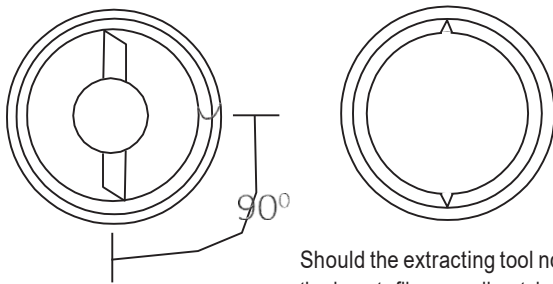

Should the extracting tool not grip the insert, file a small notch in the insert for the tool to bite into.



Extraction Tools

Recoil Removal Tool Part Numbers - Tanged

Size/Pitch	Tangless		Tanged
	Removal Tool	Replacement Pawl Kit	Removal Tool
Metric			
M2 - 0.4	2KRTM-2	2KRPM-2	50002
M2.2 - 0.45	-	-	50002
M2.5 - 0.45	2KRTM-2.5	2KRPM-M2.5	50002
M3 - 0.5	2KRTM-3	2KRPM-M3	50002
M3.5 - 0.6	-	-	50002
M4 - 0.7	2KRTM-4	2KRPM-M4	50003
M5 - 0.8	2KRTM-5	2KRPM-M5	50003
M6 - 1	2KRTM-6	2KRPM-M6	50003
M7 - 1.0	-	-	50003
M8 - 0.75	-	-	50003
M8 - 1	-	-	50003
M8 - 1.25	2KRTM-8	2KRPM-M8	50003
M9 - 1	-	-	50003
M9 - 1.25	-	-	50003
M10 - 1	-	-	50003
M10 - 1.25	-	-	50003
M10 - 1.5	2KRTM-10	2KRPM-M10	50003
M12 - 1	-	-	50003
M12 - 1.25	-	-	50003
M12 - 1.5	-	-	50003
M12 - 1.75	2KRTM-12	2KRPM-M12	50003
M13 - 1.25	-	-	50003
M13 - 1.5	-	-	50003
M13 - 1.75	-	-	50003
M14 - 1.25	-	-	50003
M14 - 1.5	-	-	50003
M14 - 2	-	-	50003
M15 - 1.25	-	-	50003
M15 - 1.5	-	-	50003
M15 - 2	-	-	50003
M16 - 1.5	-	-	50003
M18 - 1.5	-	-	50003
M18 - 2	-	-	50003
M18 - 2.5	-	-	50003
M20 - 1.5	-	-	50004
M20 - 2	-	-	50004
M20 - 2.5	-	-	50004

Diagram of Recoil Removal Tool Part Number example

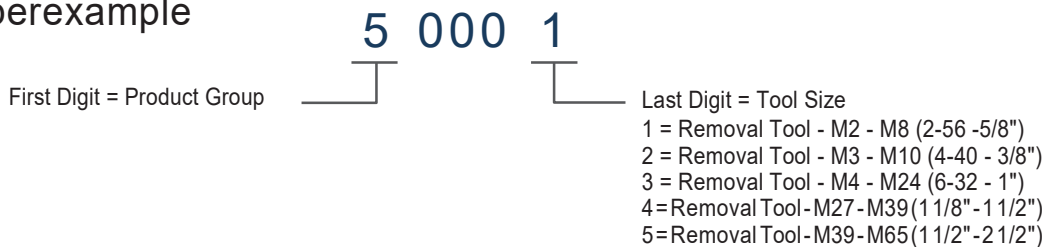

Recoil® Removal Tool Part Numbers - Tanged and Tangless®

Size/Pitch	Tangless		Tanged
	Removal Tool	Replacement Pawl Kit	Removal Tool
Metric			
M22 - 1.5	-	-	50004
M22 - 2	-	-	50004
M22 - 2.5	-	-	50004
M24 - 1.5	-	-	50004
M24 - 2	-	-	50004
M24 - 3	-	-	50004
M26 - 1.5	-	-	50004
M27 - 1.5	-	-	50004
M27 - 2	-	-	50004
M27 - 3	-	-	50004
M30 - 1.5	-	-	50004
M30 - 2	-	-	50004
M30 - 3	-	-	50004
M30 - 3.5	-	-	50004
M33 - 2	-	-	50004
M33 - 3.5	-	-	50004
M36 - 1.5	-	-	50004
M36 - 3	-	-	50004
M36 - 4	-	-	50004
M39 - 2	-	-	50004
M39 - 3	-	-	50004
M39 - 4	-	-	50004
M42 - 2	-	-	50005
M42 - 3	-	-	50005
M42 - 4	-	-	50005
M42 - 4.5	-	-	50005
M45 - 3	-	-	50005
M45 - 4.5	-	-	50005
M48 - 3	-	-	50005
M48 - 4	-	-	50005
M48 - 5	-	-	50005
M52 - 3	-	-	50005
M52 - 5	-	-	50005

Size/Pitch	Tangless		Tanged
	Removal Tool	Replacement Pawl Kit	Removal Tool
Unified Coarse			
#2 - 56	TL53523	TL53524K	50002
#3 - 48	-	-	50002
#4 - 40	TL53543	TL53544K	50002
#5 - 40	-	-	50002
#6 - 32	TL53563	TL53564K	50002
#8 - 32	TL53583	TL53584K	50002
#10 - 24	2KRTC-3*	2KRPC-3K*	50002
#12 - 24	-	-	50002
1/4 - 20	2KRTC-4*	2KRPC-4K*	50002
5/16 - 18	2KRTC-5*	2KRPC-5K*	50002
3/8 - 16	2KRTC-6*	2KRPC-6K*	50002
7/16 - 14	-	-	50003
1/2 - 13	TL53087	TL53082K	50003
9/16 - 12	-	-	50003
5/8 - 11	-	-	50003
3/4 - 10	-	-	50003
7/8 - 9	-	-	50003
1 - 8	-	-	50003
1 1/8 - 7	-	-	50004
1 1/4 - 7	-	-	50004
1 3/8 - 6	-	-	50004
1 1/2 - 6	-	-	50004
Unified Fine			
#3 - 56	-	-	50002
#4 - 48	-	-	50002
#6 - 40	-	-	50002
#8 - 36	-	-	50002
#10 - 32	TL54603	TL54604K	50002
1/4 - 28	2KRTF-4*	2KRPF-4K*	50002
5/16 - 24	2KRTF-5*	2KRPF-5K*	50002
3/8 - 24	2KRTF-6*	2KRPF-6K*	50002
7/16 - 20	-	-	50002
1/2 - 20	-	-	50003
9/16 - 18	-	-	50003
5/8 - 18	-	-	50003
3/4 - 16	-	-	50003
7/8 - 14	-	-	50003
1 - 12	-	-	50003
1 - 14	-	-	50004
1 1/8 - 12	-	-	50004
1 1/4 - 12	-	-	50004
1 3/8 - 12	-	-	50004
1 1/2 - 12	-	-	50004



Recoil® Kits and Hand Installation Tools

Trade Series Kit / Range Kit

Recoil's innovative and cost-effective thread repair kits are utilized worldwide in industrial and automotive maintenance situations. Each kit contains:

- 1 New combo tap and installation tool
- tap wrench no longer required
- 2 Magnetic Tang Break Tool - for easy tang removal in blind holes
- 3 H.S.S. Drill



Trade Series Kit/Pro XL

Range Kit

Spark Plug Kit

Spark plug kits have pilot nose taps for accurate self alignment eliminating the need for drilling. The table below denotes the Recoil Insert Kit part numbers for each available thread size together with details of insert quantities included with each thread repair kit.



Spark Plug Kit

Recoil Tools

Arconic Fastening Systems supplies a range of associated Recoil tooling to facilitate Recoil insert installation. The advantage of the Recoil tooling system is its simplicity, versatility, and ease of use. The hand installation tooling range includes the manual installation tool, the semi production "Prewinder" type, as well as manual and spring operated tang break off tools.

Manual Installation Tool

The standard Recoil insert installation tool is the most practical and simple to use for general applications. This tool may be used to install 1D through to 3D length inserts, but care must be taken to ensure that the adjustable collar is correctly set to suit the particular type and length of the Recoil insert. If the collar is incorrectly set, the insert will not drive properly and the tool may slip off the tang as the insert enters the hole. For general use, the collar should be adjusted such that the insert tang is positioned mid-way along the slot with the insert coils compressed. This will allow the insert free movement to suit the parent material thread pitch during installation.

If the installation tool is used to break off the tang, then it must be lifted clear of the insert following installation and replaced into the insert at 90 degrees to its drive position. This ensures that the tool is correctly placed on the insert tang. Tap the tool sharply downward to produce a clean tang break.



Manual Installation Tool (Type 1)



Manual Installation Tool (Type 2)

Note: The manual installation tool is not recommended for the installation of locking inserts.

Recoil manual tools are not recommended for use with other brands of wire thread inserts.

* Tap Square is only suitable for non-ferrous alloys. Tap drive, tang break and drill only up to 1/2"

Recoil® Kits and Hand Installation Tool Part Numbers

Thread Size/Pitch	Trade Series Kit	Trade Series No. of Inserts	Type	Installation Tool
Metric				
M2 - 0.4	35028 *	15	1	50061-20
M2.2 - 0.45	35018 *	15	1	50061-21
M2.5 - 0.45	35258 *	15	1	50069-21
M3 - 0.5	35038 *	15	1	50089-17
M3.5 - 0.6	35358 *	15	1	50095-15
M4 - 0.7	35048 *	15	1	50125-13
M5 - 0.8	35058 *	15	1	50156-9
M6 - 1	35068 *	15	1	50188-5
M7 - 1	35078 *	15	1	50219-4
M8 - 1	37088 *	15	1	50250-7
M8 - 1.25	35088 *	15	1	50250-7
M9 - 1	37098 *	10	1	50281-5
M9 - 1.25	35098 *	15	1	50281-5
M10 - 1	38108 *	10	1	50313-12
M10 - 1.25	37108 *	10	1	50313-4
M10 - 1.5	35108 *	10	1	50281-4
M11 - 1	38118 *	10	1	50344-4
M11 - 1.25	37118 *	10	1	50344-4
M11 - 1.5	35118 *	10	1	50344-4
M12 - 1.25	38128 *	10	1	50375-1
M12 - 1.5	37128 *	10	1	50375-1
M12 - 1.75	35128 *	10	1	50375-1
M13 - 1.25	38138	6	1	50375-0
M13 - 1.5	37138	6	1	50375-0
M13 - 1.75	35138	6	1	50375-0
M14 - 1.25	38148-1	6	1	50468-0
M14 - 1.5	37148	6	1	50438-0
M14 - 2	35148	6	1	50438-0
M15 - 1.5	37158	6	1	50438-0
M15 - 2	35158	6	1	50438-0
M16 - 1.5	37168	6	1	50500-0
M16 - 2	35168	6	1	50500-0
M18 - 1.5	38188	6	1	50591-0
M18 - 2	37188	6	1	50591-0
M18 - 2.5	35188	6	1	50591-0
M20 - 1.5	38200	5	1	50591-0
M20 - 2	37208	6	1	50591-0
M20 - 2.5	35208	6	1	50591-0
M22 - 1.5	38220	5	2	50688
M22 - 2	37220	5	2	50688
M22 - 2.5	35220	5	2	50688
M24 - 1.5	38240	5	2	50750
M24 - 2	37240	5	2	50750
M24 - 3	35240	5	2	50750
M26 - 1.5	38260	5	2	50875
M27 - 1.5	38270	5	2	50875

Thread Size/Pitch	Trade Series Kit	Trade Series No. of Inserts	Type	Installation Tool
Metric				
M27 - 2	37270	5	2	50875
M27 - 3	35270	5	2	50875
M30 - 1.5	38300	5	2	51000
M30 - 2	37300	5	2	51000
M30 - 3	35300-3	5	2	51000
M30 - 3.5	35300	5	2	51000
M33 - 2	37330	5	2	51063
M33 - 3.5	35330	5	2	51063
M36 - 1.5	38360	4	2	51125
M36 - 3	37360	4	2	51125
M36 - 4	35360	4	2	51125
M39 - 2	38390	4	2	51250
M39 - 3	37390	4	2	51250
M39 - 4	35390	4	2	51250
M42 - 2	38420	4	2	51250
M42 - 3	37420	4	2	51250
M42 - 4	35420-4	4	2	51250
M42 - 4.5	35420	4	2	51250
M45 - 3	N/A		2	51250
M45 - 4.5	35450	4	2	51250
M48 - 3	N/A		2	51500
M48 - 4	N/A		2	51500
M48 - 5	N/A		2	51500
M52 - 3	N/A		2	51500
M52 - 5	N/A		2	51500

* Drill and Magnetic Tangbreak Tool included in Kit



Trade Series / Pro XL Kit

Recoil® Kits and Hand Installation Tool Part Numbers

Thread Size/Pitch	Trade Series Kit	Trade Series No. of Inserts	Type	Installation Tool
BSW				
1/8 - 40	32028 *	15	1	50089-19
3/16 - 24	32038 *	15	1	50140-9
1/4 - 20	32048 *	15	1	50188-5
5/16 - 18	32058 *	15	1	50219-8
3/8 - 16	32068 *	10	1	50281-4
7/16 - 14	32078 *	10	1	50344-1
1/2 - 12	32088 *	10	1	50375-1
9/16 - 12	32098	6	1	50438-0
5/8 - 11	33108	6	1	50500-0
3/4 - 10	32128	6	1	50591-0
7/8 - 9	32140	5	2	50688
1" - 8	32160	5	2	50750
1 1/8 - 7	32180	5	2	50875
1 1/4 - 7	32200	5	2	51000
1 3/8 - 6	32220	5	2	50875
1 1/2 - 6	32240	5	2	51125
BA				
0BA	30508 *	15	1	50188-5
2BA	30528 *	15	1	50140-9
4BA	30548 *	15	1	50095-15
6BA	30568 *	15	1	50077-17
BSF				
3/16 - 32	30038 *	15	1	50156-9
1/4 - 26	30048 *	15	1	50188-5
5/16 - 22	30058 *	15	1	50250-5
3/8 - 20	30068 *	10	1	50281-5
7/16 - 18	30078 *	10	1	50344-4
1/2 - 16	30088 *	10	1	50375-1
9/16 - 16	30098	6	1	50438-0
5/8 - 14	30108	6	1	50500-0
3/4 - 12	30128	6	1	50591-0
7/8 - 11	30140	5	2	50688
1" - 10	30160	5	2	50750
1 1/4 - 9	30200	5	2	51000

Thread Size/Pitch	Trade Series Kit	Trade Series No. of Inserts	Type	Installation Tool
BSC				
5/16 - 26	36508 *	15	1	50250-4
3/8 - 26	36608 *	10	1	50313-5
7/16 - 26	36708 *	10	1	50344-4
1/2 - 26	36808 *	10	1	50375-1
BSP				
1/8 - 28	31028 *	10	1	50313-5
1/4 - 19	31048	10	1	50438-0
3/8 - 19	31068	6	1	50500-0
1/2 - 14	31080	5	2	50688
5/8 - 14	31100	5	2	50875
3/4 - 14	31120	5	2	51125
1" - 11	31160	5	2	51125
NPT				
1/8 - 27	36028 *	10	1	50313-1
1/4 - 18	36048	10	1	50438-0
3/8 - 18	36068	6	1	50500-0
1/2 - 14	36080	5	2	50688
3/4 - 14	36120	5	2	50875
1 - 11 1/2	36160	5	2	51125
8 TPI UN				
1 1/8 - 8	36180	5	2	50875
1 1/4 - 8	36200	5	2	51000
1 3/8 - 8	36220	5	2	51063
1 1/2 - 8	36240	4	2	51125
1 5/8 - 8	36260	4	2	51250
1 3/4 - 8	36280	4	2	51250
1 7/8 - 8	36300	4	2	51500
2" - 8	36320	4	2	51500

* Drill and Magnetic Tangbreak Tool included in Kit

How to place the insert on the Hand Tool

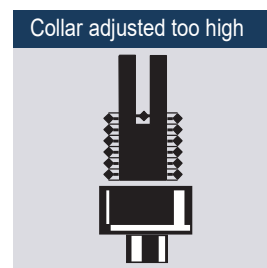
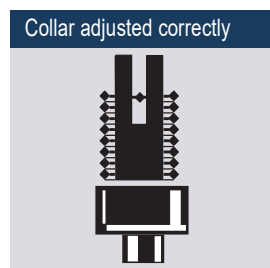
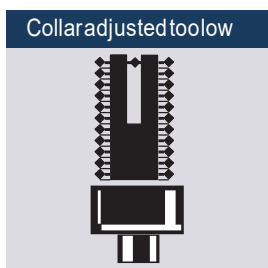

Recoil® Kits and Hand Installation Tool Part Numbers

Thread Size/Pitch	Trade Series Kit	Trade Series No. of Inserts	Type	Installation Tool
Unified Coarse				
#2 - 56	33528 *	15	1	50061-17
#3 - 48	33538 *	15	1	50069-17
#4 - 40	33548 *	15	1	50077-17
#5 - 40	33558 *	15	1	50089-18
#6 - 32	33568 *	15	1	50095-16
#8 - 32	33588 *	15	1	50125-14
#10 - 24	33608 *	15	1	50140-11
#12 - 24	33628 *	15	1	50156-10
1/4 - 20	33048 *	15	1	50188-10
5/16 - 18	33058 *	15	1	50219-8
3/8 - 16	33068 *	15	1	50281-4
7/16 - 14	33078 *	10	1	50344-3
1/2 - 13	33088 *	10	1	50375-2
9/16 - 12	33098	6	1	50438-0
5/8 - 11	33108	6	1	50500-0
11/16 - 11	33110	6	1	50500-0
3/4 - 10	33128	6	1	50591-0
7/8 - 9	33140	5	2	50688
1" - 8	33160	5	2	50750
1 1/8 - 7	33180	5	2	50875
1 1/4 - 7	33200	5	2	51000
1 3/8 - 6	33220	5	2	51063
1 1/2 - 6	33240	4	2	51125

Thread Size/Pitch	Trade Series Kit	Trade Series No. of Inserts	Type	Installation Tool
Unified Fine				
#3 - 56	34538 *	15	1	50069-17
#4 - 48	34548 *	15	1	50077-17
#6 - 40	34568 *	15	1	50095-17
#8 - 36	34588 *	15	1	50125-14
#10 - 32	34608 *	15	1	50156-11
#12 - 28	34628 *	15	1	50156-10
1/4 - 28	34048 *	15	1	50188-10
5/16 - 24	34058 *	15	1	50250-8
3/8 - 24	34068 *	15	1	50313-6
7/16 - 20	34078 *	10	1	50344-4
1/2 - 20	34088 *	10	1	50375-3
9/16 - 18	34098	6	1	50438-0
5/8 - 18	34108	6	1	50500-0
3/4 - 16	34128	6	1	50591-0
7/8 - 14	34140	5	2	50688
1" - 12	34160	5	2	50750
1" - 14	34160-14	5	2	50750
1 1/8 - 12	34180	5	2	51000
1 1/4 - 12	34200	5	2	51063
1 3/8 - 12	34220	3	2	51125
1 1/2 - 12	34240	3	2	51250

* Drill and Magnetic Tangbreak Tool included in Kit

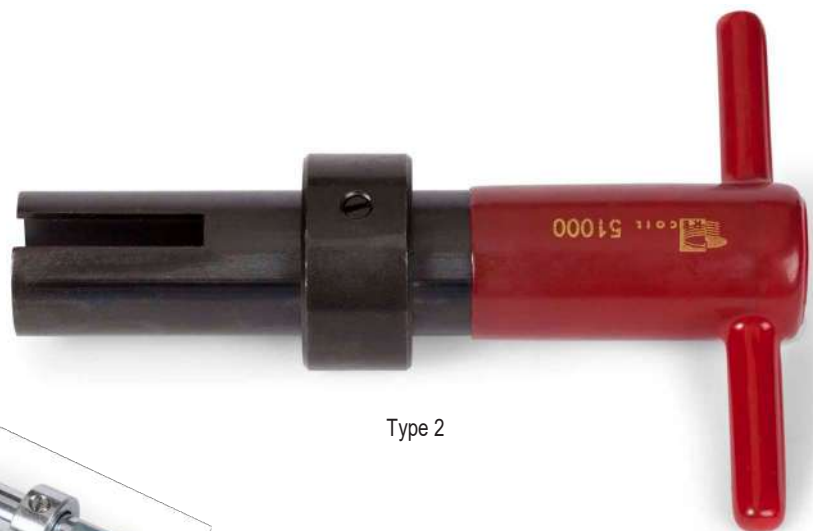

Design Considerations

The following design considerations should be evaluated to maximize the security and safety of the fastening assembly using Recoil® wire inserts.

Boss Dimensions

Boss thickness is a function of size and strength requirements and also design of components. For optimum strength, the minimum wall thickness should be twice the maximum diameter of the STI Recoil Tap. For minimum requirements, a wall thickness of twice the bolt diameter to center line may be adequate.

Edge Dimensions

The minimum edge distance recommended is the maximum diameter of the STI tap measured from the edge of the material to the center-line of the hole.

Minimum Material Thickness

The recommended minimum material thickness for through-hole applications is equal to the nominal length of the insert plus one pitch. This allows for proper countersinking and installation of the insert at 3/4 to 1-1/2 pitches below the surface of the component. In design critical applications, the minimum thickness may be reduced by eliminating the countersink and installing the insert to 1/4 to 1/2 pitch below the surface.

Class of Thread Fit

All Recoil inserts are produced to exacting tolerances where installation into the tapped hole will conform exactly to the parent material thread characteristics. It is therefore important that the tapped hole tolerances of either 2B or 3B (unified threads), or the applicable 4H5H and 5H (metric threads) combinations must be carefully controlled by precise tapping and gauging operations.

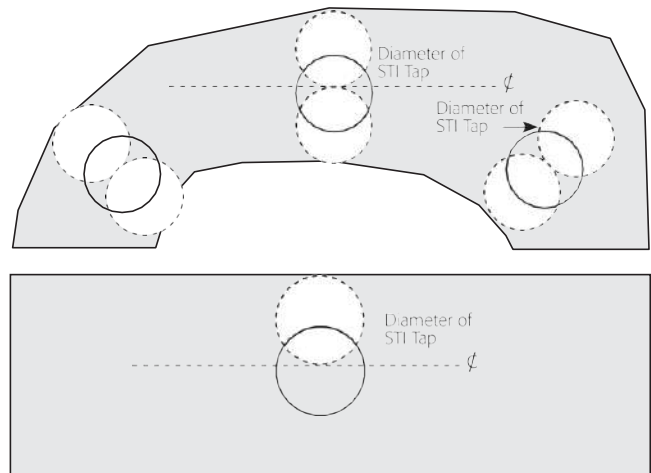

Gauging

Recoil inserts, when installed correctly in tapped and gauged holes, will conform with the tapped hole dimensions once the insert has been seated. Gauging of the tapped hole with the appropriate gauges prior to installing Recoil inserts is therefore highly recommended.

Bolt Engagement

Maximum strength of the bolted insert assembly will be achieved if the bolt or screw engages the full length of the insert. Ideally, the minimum bolt projection for safe engagement should be at least two pitches beyond the last coil of the insert.

Tang Removal

To achieve the optimum bolt engagement and hence maximum strength, the tang should be removed from the insert. Exceptions to this recommendation may be necessary in certain blind-hole applications

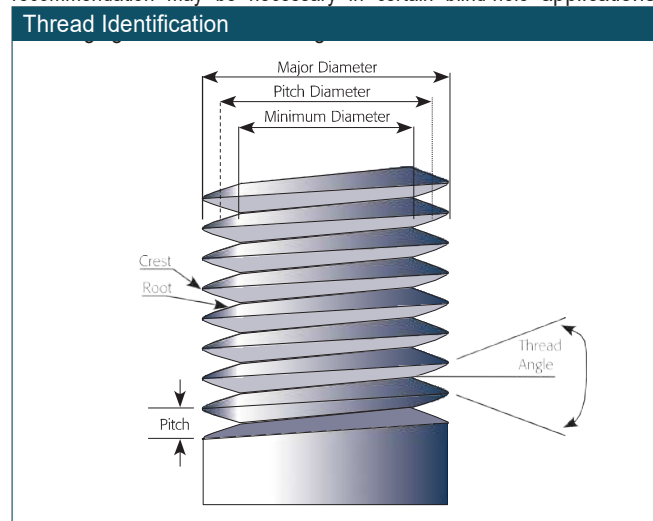
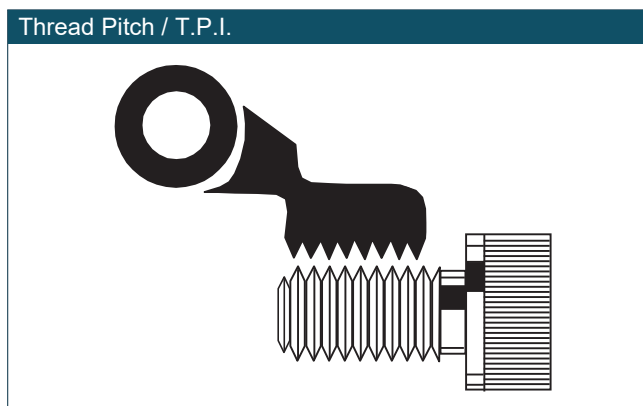

Assembly Design

Design Method

The ultimate consideration is to design an assembly that balances the tensile strength of the bolt material against the shear strength of the parent material. With insert lengths available in 1, 1-1/2, 2, 2-1/2, and 3 times the nominal thread diameters, there are engagement lengths available to produce an assembly thread system where the bolt will fail without damage to the parent material or thread. The bolt must be fully engaged along the entire length of the insert to obtain this position.

Selection of the correct length insert can be determined from Table 1 referring to values for bolt ultimate strengths and parent material shear strengths. For intermediate strength value, use the next higher bolt tensile value or the next lower parent material shear strength.

Assembly strength is a function of shear area and the shear strength of the parent material, tensile strength and cross sectional area of the bolt. Table 1 provides a recommendation of the nominal length of insert which should be selected for a parent material of a certain shear strength, so that when a bolt is used with defined tensile properties, tensile failure of the bolt should occur before the insert is stripped away from the material in which it was inserted.

Table 1 - Lengths of Thread Engagement in Terms of Nominal Thread Size

Shear Strength of Parent Material MPa /1/	Bolt Ultimate Tensile Strength MPa 300 Nominal Insert Length-Diameters	Bolt Ultimate Tensile Strength MPa 400 Nominal Insert Length-Diameters	Bolt Ultimate Tensile Strength MPa 500 Nominal Insert Length-Diameters	Bolt Ultimate Tensile Strength MPa 600 Nominal Insert Length-Diameters	Bolt Ultimate Tensile Strength MPa 900 Nominal Insert Length-Diameters	Bolt Ultimate Tensile Strength MPa 1100 Nominal Insert Length-Diameters	Bolt Ultimate Tensile Strength MPa 1250 Nominal Insert Length-Diameters	Bolt Ultimate Tensile Strength MPa 1550 Nominal Insert Length-Diameters	Bolt Ultimate Tensile Strength MPa 1800 Nominal Insert Length-Diameters
70	1.5	2	2.5	2.5	-	-	-	-	-
100	1	1.5	1.5	2	3	-	-	-	-
150	1	1	1.5	1.5	2	2.5	3	-	-
200	1	1	1	1	1.5	2	2	2.5	3
250	1	1	1	1	1.5	1.5	2	2	2.5
300	1	1	1	1	1	1.5	1.5	2	2
350	1	1	1	1	1	1	1.5	1.5	2

Design Method

The following procedure can be used to verify a joint design incorporating a wire thread insert:

1. Select size and strength of bolt to be used (refer to table 2).
2. Determine tensile failure load of the selected bolt.
3. Determine shear strength of parent material for the installation of the insert (refer to table 3).

4. Determine length of insert based on the shear strength capability of parent material.

Note: Information in referring to joint strength is intended as a guide only. Professional engineering advice must be sought when exact design calculations are required.

Step 1: Select size and strength of bolt to be used

Design Example (Metric) Units		Design Example (Inch) Units	
Type	M16-2.0 Socket Head Cap Screw	Type	1/2-13 UNC SAE Grade 8
Nominal Diameter	16.0 mm	Nominal Diameter	0.500 "
Pitch	2.0 mm	TPI	13
Shear Strength	1034 MPa (refer table 2)	Tensile Strength	181,000 psi (refer table 2)

Assembly Design

Table 2 Strength, Bolt (Metric)

Bolt Grade	Sizes	Tensile Strength MPa (minimum)
SAE Grade 1	1/4 to 1"	413
SAE Grade 5	1/4 to 1 1/2"	827
SAE Grade 7	1/4 to 1 1/2"	917
SAE Grade 8	1/4 to 1 1/2"	1034
ASTM A354	BC 1/4 to 2 1/2"	862
	BD 1/4 to 2 1/2"	1034
Socket head screw products		1250

Step 2: Determine tensile failure load of selected bolt

Min Thread Diameter	Shear Area	Tensile Failure Load
13.97mm (handbook)	149.5mm ² (calculated)*	154.59kN (calculated)#

*Area based on minor thread diameter.
#Parent material shear strength must exceed this.

Table 2 Strength, Bolt (Inch)

Bolt Grade	Sizes	Tensile Strength psi (minimum)
SAE Grade 1	1/4 to 1"	60,000
SAE Grade 5	1/4 to 1 1/2"	120,000
SAE Grade 7	1/4 to 1 1/2"	133,000
SAE Grade 8	1/4 to 1 1/2"	150,000
ASTM A354	BC 1/4 to 2 1/2"	125,000
	BD 1/4 to 2 1/2"	150,000
Socket head screw products		181,000

Min Thread Diameter	Shear Area	Tensile Failure Load
0.407" (handbook)	0.130" (calculated)*	23,550 Pounds Force (lbf) (calculated)#

*Area based on minor thread diameter.
#Parent material shear strength must exceed this.

Step 3: Determine shear strength of parent material for the installation of the insert (refer table 3)

Type 2024 Wrought Aluminum, T62 temper
Shear Strength 283 MPa (refer table 3)

Type 5083 Wrought Aluminum, annealed Condition
Shear Strength 25,000 psi (refer table 3)

Table 3 Shear Strength, Parent Material (Metric)

Alloy	Temper	Shear Strength MPa (typical)
SHEET & PLATE		
1200	0	62
2024	T62	283
5005	H34	97
5251	H34	138
5083	0	172
5083	H321	179
7075	T6	331
EXTRUSIONS (including machine rod)		
1350	H112	55
2011	T3	221
2011	T6	234
2014	T6	290
6060	T5	117
6061	T6	207
CASTINGS (Properties refer to test bars only)		
CA401 {LM6+ A413#}	F1-Sand	125
HEAT TREATING ALLOY		
AC601 {LM25+ A356#}	T6-Sand	125
AC601 {LM25+ A356#}	T5-Sand	180
AC601 {LM25+ A356#}	T6-Perm	190

Table 3 Shear Strength, Parent Material (Inch)

Alloy	Temper	Shear Strength psi (typical)
SHEET & PLATE		
1200	0	9,000
2024	T62	41,000
5005	H34	14,000
5251	H34	20,000
5083	0	25,000
5083	H321	26,000
7075	T6	48,000
EXTRUSIONS (including machine rod)		
1350	H112	8,000
2011	T3	32,000
2011	T6	34,000
2014	T6	42,000
6060	T5	17,000
6061	T6	30,000
CASTINGS (Properties refer to test bars only)		
CA401 {LM6+ A413#}	F1-Sand	18,000
HEAT TREATING ALLOY		
AC601 {LM25+ A356#}	T6-Sand	18,000
AC601 {LM25+ A356#}	T5-Sand	26,000
AC601 {LM25+ A356#}	T6-Perm	27,000

Shear strength of standard parent materials, (indication only refer supplier for specific properties)
+Nearest British Equivalent #Nearest US Equivalent

Assembly Design

Step 4: Determine the length of insert based on shear strength of parent material

Nominal Diameter	16.0 mm (selected bolt)
Pitch	2.0 mm
Pitch Diameter (min)	17.299mm (refer taped hole data)

Nominal Diameter	0.500" (selected bolt)
TPI	13
Pitch Diameter (min)	0.550" (refer taped hole data)

$$L = \frac{\text{Tensile Strength of Bolt}}{\text{Shear Circumference Strength of Hole} \times \text{Arbitrary Constant}}$$

L = Required length of fitted insert

Arbitrary Constant = 0.5

(0.5 Based on shearing of the parent material occurring along the pitch diameter of the tapped hole)

$$L = \frac{1034 \times (13.797^2 \times \pi / 4)}{283 \times 17.299 \pi \times 0.5}$$

L = 20.1mm

Conclusion:

For this application a 16mm diameter bolt has been selected. Insert engagement of 20.1mm was calculated. The suitable diameter of the insert can be determined by dividing the length of the insert by the diameter of the bolt.

For example:

L/dia = 20.1mm/16mm
 = 1.26 select next highest size
 Therefore use a 1.5D insert

$$L = \frac{\text{Tensile Strength of Bolt}}{\text{Shear Circumference Strength of Hole} \times \text{Arbitrary Constant}}$$

L = Required length of fitted insert

Arbitrary Constant = 0.5

(0.5 Based on shearing of the parent material occurring along the pitch diameter of the tapped hole)

$$L = \frac{181,000 \times (0.4072 \times \pi / 4)}{25,000 \times 0.550 \pi \times 0.5}$$

L = 1.09"

Conclusion:

For this application a 1/2" diameter bolt has been selected. Insert engagement of 1.09" was calculated. The suitable diameter of the insert can be determined by dividing the length of the insert by the diameter of the bolt.

For example:

L/dia = 1.09"/0.5"
 = 2.2 select next highest size
 Therefore use a 2.5D insert

Assembly Design

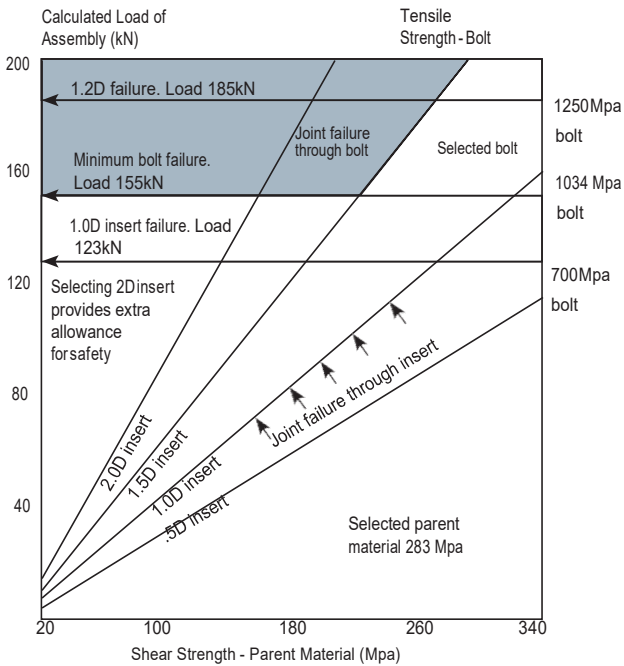

The shaded area in the graph indicates the region in which bolt failure will occur.

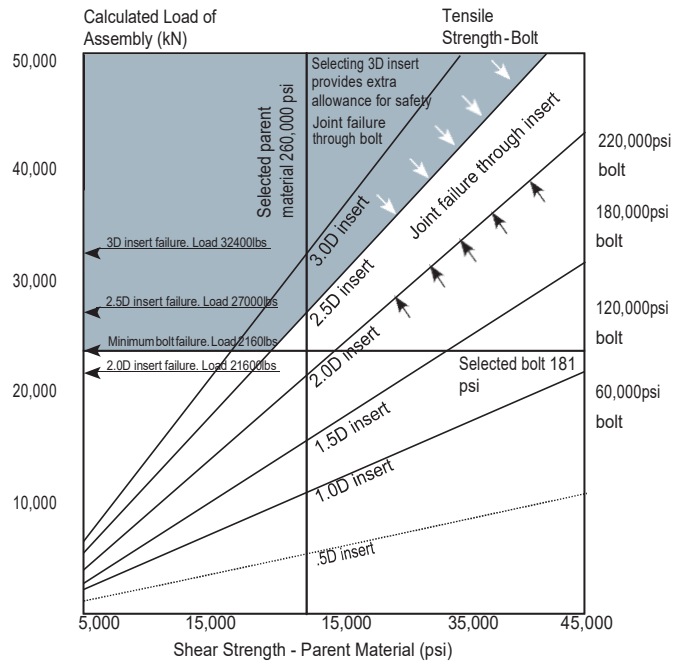

The shaded area in the graph indicates the region in which bolt failure will occur.

Note: Inserts are available in standard lengths which are multiples of the diameter. For example an insert with a length of 1.5D will measure one and a half times as long as the diameter when installed. Note: The example above is an indication only. Professional engineering advice must be sought when exact design calculations are required.

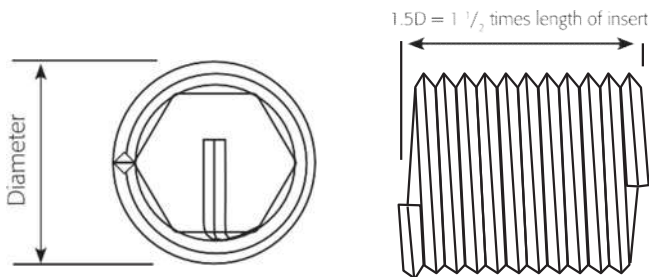

Thread Identification and Drill Chart

Metric

Diameter in Inches	Thread Size mm	ISO Coarse			Other Fine Pitch	ISO FINE			BA			Drill mm	
		Pitch	Drill Size			Pitch	Drill Size		Size	Diameter			Pitch
			Inch	mm		Inch	mm		Inch	mm			
.079	M2	.40		2.1					0	0.236	6.0	1	6.2
.087	M2.2	.45	No.42	2.3					2	0.185	4.7	0.8	4.9
.098	M2.5	.45	No.37	2.6					4	0.142	3.6	0.66	3.8
.118	M3	.5	1/8	3.2					6	0.11	2.8	0.53	2.9
.138	M3.5	.6	No.27	3.7					8	0.86	2.2	0.43	2.3
.157	M4	.7	11/64	4.2					10	0.67	1.7	0.35	1.7
.197	M5	.8	3/64	5.2									
.236	M6	1	1/4	6.3									
.276	M7	1	9/32	7.3									
.315	M8	1.25	21/64	8.3	.75	1	21/64	8.3					
.354	M9	1.25		9.4		1		9.3					
.394	M10	1.5	13/32	10.4	1*	1.25	13/32	10.25					
.433	M11	1.5		11.5	1	1.25		11.25					
.472	M12	1.75	31/64	12.5	1, 1.25*	1.5	31/64	12.25					
.512	M13	1.75		13.5	1.25	1.5		13.25					
.551	M14	2	37/64	14.5	1.25*	1.5	9/16	14.25					
.630	M16	2	21/32	16.5		1.5	21/32	16.5					
.709	M18	2.5	47/64	18.75	1.5*	2	23/32	18.5					
.787	M20	2.5	13/16	20.75	1.5	2	3/16	20.5					
.866	M22	2.5		22.75	1.5	2		22.5					
.945	M24	3		24.75	1.5	2		24.5					

* M10 - 1, M12 - 1.25, M14 - 1.25, M18 - 1.5 - Popular sparkplug sizes. Above M24 is available on request.

Thread Identification and Drill Chart

Inch

Diameter in		Thread Size	Threads Per Inch (TPI)						Drill Size					
Inches	mm		UNC	BSW (SAE)	UNF	BSF	BSP*	NPT*	UNC/BSW		UNF/SAE/BSF		BSP/NPT	
								Inch	mm	Inch	mm	Inch	mm	
.86	2.18	#2	56	40	64			3/32	2.3	No.37	2.3			
.99	2.51	#3	48		56			No.36	2.7		2.7			
.112	2.84	#4	40		48			No.31	3.0	No.31	3.0			
.125	3.17	#5, 1/8	40	40	44		28	27	No.29	3.4		3.3	3/8	9.9
.138	3.50	#6	32		40				No.25	3.7	No.26	3.7		
.164	4.16	#8	32		36				11/64	4.4	11/64	4.4		
.190	4.82	#10, 3/16	24		32				13/64	5.1	13/64	5.1		
.187	4.76	#3/16		24		32			13/64	5.0	13/64	5.0		
.216	5.49	#12, 7/32	24		28				15/64	5.6				
.250	6.35	1/4	20	20	28	26	19	18	17/64	6.7	17/64	6.6	33/64	13.5
.312	7.93	5/16	18	18	24	22			21/64	8.3	21/64	8.2		
.375	9.52	3/8	16	16	24	20	19	18	25/64	9.9	25/64	9.8	21/32	17.0
.437	11.11	7/16	14	14	20	18			29/64	11.5	29/64	11.5		
.500	12.70	1/2	13	12	20	16	14	14	17/32	13.0	33/64	13.0	13/16	21.5
.562	14.28	9/16	12	12	18	16			19/32	14.5	37/64	14.5		
.625	15.87	5/8	11	11	18	14			21/32	16.5	41/64	16.25		
.750	19.05	3/4	10	10	16	12	14	14	25/32	19.75	49/64	19.5	1 1/64	27.0
.875	22.22	7/8	9	6	14	11			29/32	23.0	57/64	22.5		
1.00	25.40	1"	8	8	12, 14	10	11	11 1/2	1 1/32	26.0	1 1/64	26.0	1 9/32	33.5
1.125	28.57	1 1/8"	7	7	12	9	11		1 5/32	29.5	1 5/32	29.5		
1.25	31.75	1 1/4"	7	7	12	9	11		1 9/32	33.0	1 9/32	32.5		
1.375	34.92	1 3/8"	6	6	12	8	11		1 13/32	36.0	1 13/32	36.0		
1.50	38.10	1 1/2"	6	6	12	8	11		1 17/32	39.0	1 17/32	39.0		

*Nominal diameters for BSP and NPT are not thread diameters but relate to the inside diameter of the pipe.

General Information

SI Units and Conversions for Characteristics of Mechanical Fasteners

Property	Unit	Symbol	Conversion		Multiply By	Approximate / Equivalent
			From	To		
Length	metre	m	inch	mm	25.4	25mm = 1 in
	centimeter	cm	inch	cm	2.54	300mm=1 ft
Mass	millimeter	mm	foot	mm	304.8	1m = 39.37
	kilogram	kg	ounce	g	28.35	28g = 1oz
	gram	g	pound	kg	.4536	1kg = 2.2lb = 35oz
Density	tonne (megagram)	t	ton (224lb)	kg	984.2	1t = 2206lbs
	kilogram per	kg/m ³	pounds per cu. ft	kg/m ³	16.02	16kg/m ³ = 1lb/ft ³
Temperature	deg. Celsius	°C	deg. Fahr	°C	(°F-32)x5/9	0°C = 32 °F
Area	square metre	m ²	sq. inch	mm ²	645.2	645mm ² = 1 in ²
	squaremillimetre	mm ²	sq. ft	m ²	.0929	1m ² = 11 ft ²
Volume	cub. metre	m ³	cu. In	mm ³	16387	16400mm ³ = 1 in ³
	cubic centimeter	cm ³	cu. Ft	m ³	.02832	1m ³ = 35ft ³
	cubic millimeter	mm ³	cu. Yd	m ³	.7645	1m ³ = 1.3yd
Force	newton	N	ounce(Force)	N	.278	1N = 3.6 ozf
	kilonewton	kN	pound(Force)	kN	.00445	4.4N = 1 lbf
	meganewton	MN	kip	MN	.00445	1kN = 225 lbf
Pressure	bar	MPa	bar	.1	1MPa = 1bar	
	megapascal	MPa	pound/in ² (psi)	MPa	.0069	1MPa = 145 psi
	newton/sqmm	N/m ²	Kip/in ² (ksi)	MPa	6.895	7MPa = 1ksi
Torque	newton-meters	N-m	inch-ounce	N-m	.00706	1N-m = 140 in.oz
			inch-pound	N-m	.113	1N-m = 9 in. ib
			foot-pound	N-m	1.356	1N-m.75 ft lb
						1.4N-m = 1 ft.lb



ARCONIC

Brinell 10m/m Ball	Rockwell			Brinell 10m/m Ball	Rockwell		
	Firth or	C. Scale 1200	B. Scale 1/16"		Firth or	C. Scale 1200	B. Scale 1/16"
3000kg load.	Vickers 120kg	Cone 150kg load.	Ball 100kg load	3000kg load.	Vickers 120kg	Cone 150kg load.	100kg load.
800	-	72	-	276	278	30	105
780	1220	71	-	269	272	29	104
760	1170	70	-	261	261	28	103
745	1114	68	-	258	258	27	102
725	1060	67	-	255	255	26	102
712	1021	66	-	249	250	25	101
682	940	65	-	245	246	24	100
688	905	64	-	240	240	23	99
652	867	63	-	237	235	22	99
262	803	62	-	229	226	21	98
614	775	61	-	224	221	20	97
601	746	60	-	217	127	19	96
590	727	59	-	211	213	18	95
576	694	57	-	206	209	17	94
552	649	56	-	203	201	16	94
545	639	55	-	200	199	15	93
529	606	54	-	196	197	14	92
514	587	53	120	191	190	13	92
502	565	52	119	187	186	12	91
495	551	51	119	185	184	11	91
477	534	49	118	183	183	10	90
461	489	47	117	175	174	7	88
444	474	46	116	170	171	6	87
427	460	45	115	167	168	5	87
415	435	44	115	165	165	4	86
401	413	43	114	163	162	3	85
388	401	42	114	160	159	2	84
374	390	41	113	156	154	1	83
370	385	40	112	154	152		-82
362	280	39	111	152	150		-82
351	361	38	111	147	147		-80
346	352	37	110	147	147		-79
331	335	36	109	143	144		-79
323	320	35	109	141	142		-77
311	312	34	108	140	135		-75
301	305	33	107	135	135		-75
293	291	32	106	130	130		-72
285	285	31	105	-	-	-	-

Speciality Fasteners International

Flat No.: #3B27, 2nd Floor, 3rd Block,
MS Industrial Complex, 488B,
14th Cross Road, 4th Phase,
Peenya Industrial Area, Peenya,
Bangalore – 560058, Karnataka, INDIA.
Tel.: +91 80 29722055
Tel.: +91 80 29722020
Fax Extention : 210
E-Mail: sales@recoil.in

GSTN Details:

GSTN No. 29ACYFS6632G1ZC
VAT/TIN: 29521308547 PAN: ACYFS6632G
IEC: 0715026381
TAN: BLRS54984G